

## STR08 Series 433MHz/868MHz +20dBm RF MCU LoRa Transceiver Modules

### Features - Radio

- 433MHz/868MHz ISM Frequency Band, LoRa and (G)FSK, (G)MSK, BPSK modem
- Data rate - up to 300kbps for (G)FSK, up to 62.5kbps for LoRa
- -146dBm receiver sensitivity (LoRa, SF-12, BW-10.4kHz)
- +20dBm RF output Power (adjustable with 1dB step size)
- Packet data, data spectrum shaping, FEC-Forward Error Correction
- Low current consumption - 4.9mA for receive mode, less than 600nA for sleep mode
- Full radio configuration/control and modem/data parameters

### Features - Microcontroller/MCU - (STM32WLE5x/STM32WLE5CCU6)

- 32-bit Arm Cortex-M4 CPU
- 48MHz clock frequency, MPU and DSP commands
- AES 256-bit encryption, RNG, CRC
- Unique device ID (IEEE802-2001 compatible 64-bit UID), 96-bit unique chip ID
- 256-Kbyte Flash, 64-Kbyte RAM, 20x32-bit backup registers
- Bootloader and OTA (over-the-air) firmware update
- 2x DMA controller (7 channel each), ADC, DAC, SPI, I2C, LPUART,
- USART, AES and timers, 2xUSART (ISO 7816, IrDA, SPI), 1xLPUART, 2xSPI, 3x I2C

### Other

- Power Supply : 1.8V~3.6V
- Operating Temperature : -40°C~+85°C
- Small profile : 43.10mmx28.60mm



MPN	Frequency	Connector
STR08RSH8	868MHz	SMA RF Connector
STR08RSH4	433MHz	SMA RF Connector
STR08CSH8	868MHz	U.FL RF Connector
STR08CSH4	433MHz	U.FL RF Connector



# STR08CSH4

## 433MHz/+20dBm STM32WLE5x MCU+LoRa RF Transceiver Module

Datasheet

## **TABLE OF CONTENTS**

1.	STR08CSH4 433MHz/+20dBm MCU+LoRa RF Transceiver Module in Brief	3
2.	STR08CSH4 Technical Data	7
3.	Programming Aspects of STR08CSH4	8
4.	Setting Modem, Transmitter & Receiver Parameters	10
5.	Module Aspects to Consider for User Application	14
6.	Test Setup & Measurement Results	19
7.	Drawings	22
8.	Ordering Information	23

Revision History

References

# 1. STR08CSH4 433MHz/+20dBm MCU+RF LoRa Transceiver Module in Brief

STR08CSH4 is a small size, compact, low power and easy to use 433MHz LoRa RF Transceiver module based on STMicroelectronics STM32WLE5CCU6 Sub-GHz RF MCU Transceiver IC. It supports LoRa, G(FSK), G(MSK) and BPSK modulations, provides radio configuration and control via the SPI interface and has up to -146dBm RF receiver sensitivity and up to +20dBm RF output power programmable in 1dB steps.

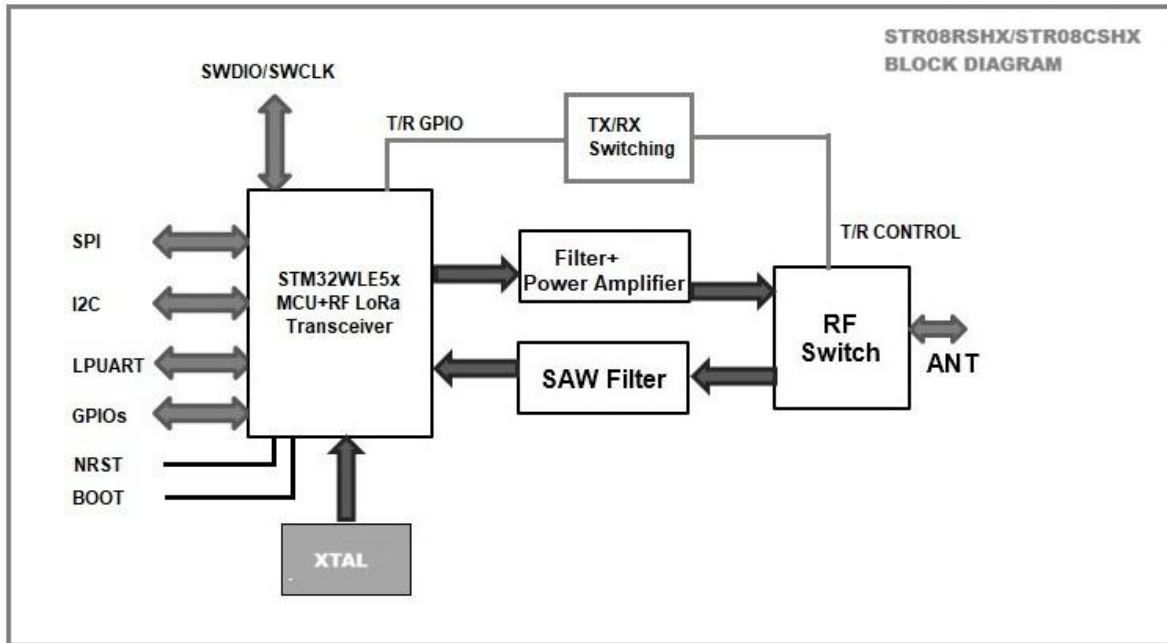

Fig.1 STR08CSH4 functional blocks and interconnections

## Features

### Radio

- Operating frequency 433MHz with LoRa and (G)FSK, (G)MSK, BPSK modem
- Up to 62.5kbps bit rate for LoRa and up to 300kps bit rate for (G)FSK
- Packet mode with data buffer, data whitening codec, FEC-Forward Error Correction
- -146dBm Receiver sensitivity, (@SF12 and LoRa BW-10.4kHz)
- +20dBm (100mWatt) RF output power, adjustable with 1dB steps
- Full radio configuration and control
- Fully programmable frequency, modem, packet parameters and radio operational modes

### MCU

- 32-bit Arm Cortex-M4 CPU
- 48MHz clock, MPU and DSP commands
- AES 256-bit encryption, RNG, CRC
- Unique device ID (IEEE802-2001 compliant 64-bit UID), 96-bit unique chip
- 256-Kbyte Flash, 64-Kbyte RAM, 20x32-bit backup memory
- Bootloader and OTA (over-the-air) firmware update
- 2x DMA controller (each - 7 channel), ADC, DAC, SPI, I2C, LPUART,
- USART, AES and timers, 2xUSART (ISO 7816, IrDA, SPI), 1xLPUART, 2xSPI, 3x I2C

### General

- Wide supply range, 1.8V~3.3V operation
- Operating Temperature, -40°C~+85°C
- Low power consumption,
  - 4.8mA in receive mode, 90mA in transmit mode(@20dBm)
- Small Size - 43.86mmx28.47mm

**Application Areas**

- Low-cost consumer electronics applications, ISM band data communication
- Smart Building Automation
- Industrial Monitoring and Control
- Remote Control, Remote Keyless Entry, Remote AMR, Tag Reader
- Wireless Alarm and Security, Wireless Sensor Node



**Fig.2 STR08CSH4 433MHz/+20dBm RF LoRa Transceiver Module**

**LoRa Modulation Technique**

The STR08CSH4 uses Semtech’s patented LoRa modulation technique which combines spread spectrum modulation and forward error correction techniques to increase the range and robustness of radio communication links compared with traditional FSK or OOK based modulation. This high sensitivity, in contrast to conventional modulation techniques, permits an increase in link budget and increased immunity to in-band interference, combined with +20dBm RF power output yields industry leading link budget.

LoRa also provides significant advantages in both blocking and selectivity, solving the traditional design compromise between range, interference immunity and energy consumption. In LoRa mode the STR08CSH4 offers ten bandwidth options as in the table below.

Signal Bandwidth	0	1	2	3	4	5	6	7	8	9
BW_L (kHz)	7.81	10.42	15.63	20.83	31.25	41.67	62.5	125	250	500

**Table 1. STR08CSH4 LoRa Mode BW Options**

The spread spectrum LoRa modulation is performed by representing each bit of payload information by multiple chips of information. The rate at which the spread information is sent is referred to as the symbol rate (Rs), the ratio between the nominal symbol rate and chip rate is the spreading factor and represents the number of symbols sent per bit of information. The range of parameters which can be configured are given in the following tables.

Spreading Factor (SF)	5	6	7	8	9	10	11	12
Chips/Symbol	32	64	128	256	512	1024	2048	4096
SNR (dB)	-2.5	-5.0	-7.5	-10.0	-12.5	-15.0	-17.5	-20.0

**Table 2. STR08CSH4 LoRa Mode Spreading Factors**

Note that the spreading factor must be known in advance on both transmit and receive sides of the radio link as different spreading factors are orthogonal to each other. Note also the resulting signal to noise ratio (SNR) required at the receiver input. It is the capability to receive signals with negative SNR that increases the sensitivity, so link budget and range, of the LoRa receiver.

To further improve the robustness of the radio link, STR08CSH4 provides cyclic error coding with different coding rates. By using this coding scheme forward error detection and correction can be applied.

**Differentiating Aspects of The STR08CSH4 433MHz LoRa RF Transceiver Module**

Main performance contributors of STR08CSH4 are the use of harmonic filters for transmitter harmonic suppression and use of 433MHz SAW filter in RX path providing high selectivity which consequently providing high interference immunity and high sensitivity resulting in long range and exceptional bit error rate performance even in highly interfering environments with low SNR/SINR values, SAW filter characteristics are given below.

STR08CSH4 is optimized for +20dBm RF power output, PA settings should be arranged according to Section 4. Setting Modem, Transmitter & Receiver Parameters as in Table12B, for other PA configuration settings matching is not optimum and the RF power output may be different from intended usually at a higher current consumption.

**433MHz SAW Filter for High Selectivity and Interference Immunity**

STR08CSH4 includes a highly selective 433MHz SAW filter in RF frontend in RX path for additional interference suppression. The characteristics of the SAW filter are given in Table 3 and Fig 4 below.

Parameter	Test Conditions	Min	Typical	Max	Unit
Center Frequency		-	435	-	MHz
3-dB Bandwidth		-	23	-	MHz
Attenuation	0 to 386MHz	45	54		dB
	386MHz to 396MHz	46	52		
	474MHz to 480MHz	45	54		
	480 to 680MHz	45	50		
	680 to 1000MHz	35	46		

**Table 3. STR08CSH4 SAW Filter Characteristics**

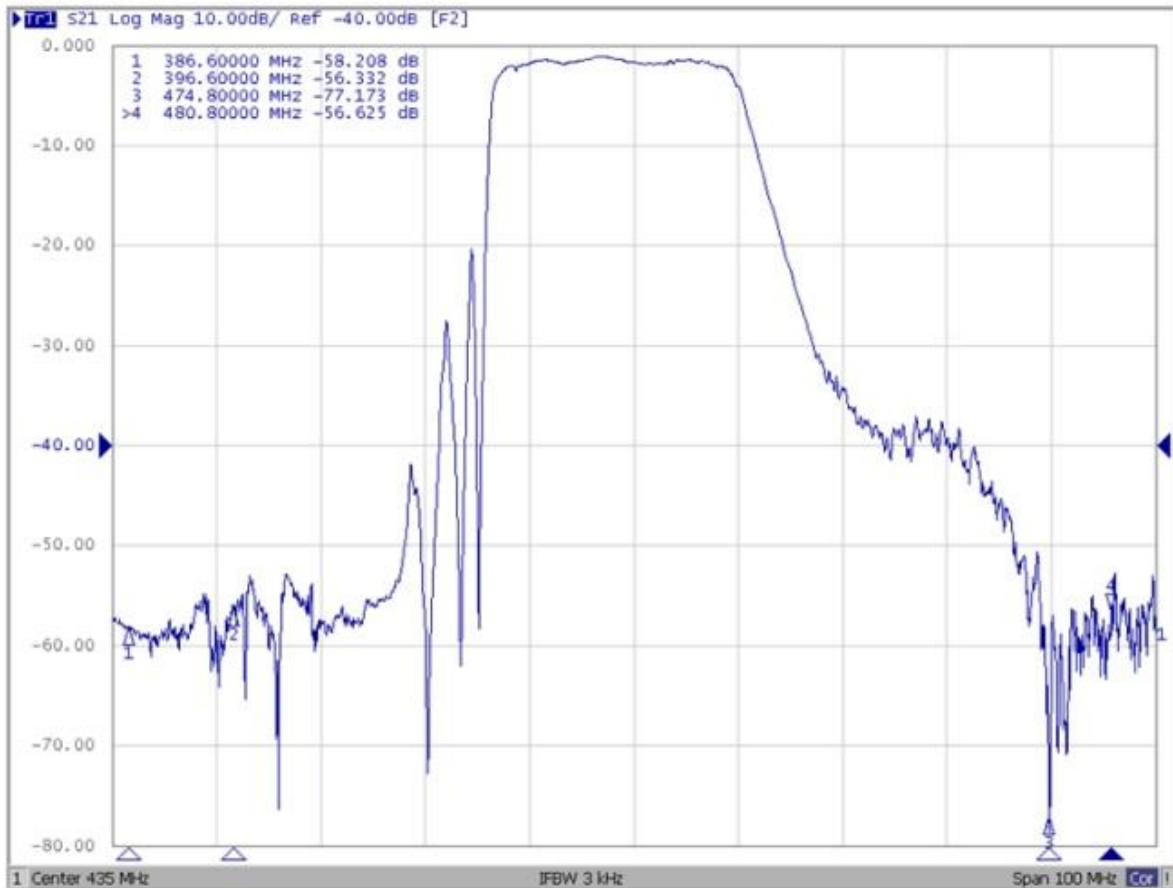

**Fig.3 STR08CSH4 RF Frontend SAW Filter Frequency Response**

Due to highly selective SAW filter use, severe performance degradations might be expected when operating frequency selected does not fit inside filter BW, therefore for optimal receiver performance an operating frequency in 432MHz-436MHz range should be selected.

## 2. STR08CSH4 Technical Data - Radio

The tables below give the electrical specifications for the STR08CSH4 433MHz MCU+RF LoRa Transceiver Module operating with LoRa, (G)FSK, (G)MSK and BPSK modulation.

Symbol	Parameter	Test Conditions	Min	Typical	Max	Unit
$F_{op}$	Operational Frequency/Band	-	-	433	-	MHz
$S_{RFIN-FSK}$	Sensitivity-FSK	@4.8kbps, BW-20kHz	-	-117	-	dBm
		@0.6kbps, BW-4kHz	-	-122	-	
$S_{RFIN-LoRa}$	Sensitivity-LoRa	@SF12, BW-10.4kHz	-	-146	-	dBm
		@SF7, BW-500kHz	-	-116	-	
$CCR_{FSK}$	Co-channel Rejection-FSK			-9		dB
$CCR_{LoRa}$	Co-channel Rejection-LoRa	@SF12		19		dB
$ACR_{FSK}$	Adjacent-channel Rejection-FSK	+/-50kHz offset		45		dB
$ACR_{LoRa}$	Adjacent-channel Rejection-LoRa	+/-187kHz offset, SF-12		72		dB
$BI_{FSK}$	Blocking Immunity-FSK (4.8kbps, BW-20kHz)	+/-1MHz offset		68		dB
		+/-2MHz offset		70		
		+/-10MHz offset		80		
$BI_{LoRa}$	Blocking Immunity-LoRa (SF12, BW-125kHz)	+/-1MHz offset		88		dB
		+/-2MHz offset		90		
		+/-10MHz offset		99		
$IMA$	Image Attenuation-LoRa	with IQ calibration		54		dB
$IIP_3$	Third Order Intercept Point	Two tone test (1MHz/1.96MHz)	-	-5	-	dBm

**Table 4. RF Radio Receiver/Receive Mode Characteristics**

Symbol	Parameter	Test Conditions	Min	Typical	Max	Unit
$F_{op}$	Operational Frequency/Band	-	-	433	-	MHz
$P_{RFOUT}$	Maximum Output Power	-	-	+20	-	dBm
$P_{RF-sat}$	Power Change Step Size	Programmable	-	1	-	dB
$P_{STEP}$	RF Output Power Range	Programmable	-11	-	+20	dBm
$P_{RMP}$	RF Output Power Ramping Time	Programmable	10	-	3400	usec

**Table 5. RF Radio Transmitter/Transmit Mode Characteristics**

Symbol	Parameter	Test Conditions	Min	Typical	Max	Unit
$F_{step}$	Synthesizer Frequency Step Size	-	-	0.95	-	Hz
$SF_{LoRa}$	Spreading Factor-LoRa	Programmable	5	-	12	-
$BR_{LoRa}$	Bit Rate-LoRa	Programmable	0.018	-	62.5	kbps
$BW_{LoRa}$	Bandwidth-LoRa	Programmable	7.8	-	500	kHz
$BR_{FSK}$	Bit Rate-FSK	Programmable	0.6	-	300	kbps
$FDA_{FSK}$	Frequency Deviation-FSK	Programmable	0.6	-	200	kHz

**Table 6. LoRa/FSK Modem and Frequency Synthesizer Characteristics**

Symbol	Parameter	Test Conditions	Min	Typical	Max	Unit
$V_{IH}$	Input High Voltage		0.7*VCC	-	VCC+0.3	V
$V_{IL}$	Input Low Voltage		-0.3	-	0.3*VCC	V
$V_{OH}$	Output High Voltage		0.9*VCC	-	VCC	V
$V_{OL}$	Output Low Voltage		0	-	0.1*VCC	V
$V_{IL\_NRST}$	Input High Voltage for NRST		-0.3	-	0.2*VCC	V

**Table 7. Digital I/O Characteristics**

Symbol	Parameter	Test Conditions	Min	Typical	Max	Unit
$V_{cc}$	Supply Voltage	-	-	3.3	-	V
$I_{dd\_SLP}$	Current–Sleep mode	-	-	600	-	nA
$I_{dd\_TX}$	Current–Transmit mode	-	-	90	-	mA
$I_{dd\_RX}$	Current–Receive mode	-	-	4.8	-	mA
$T_{op}$	Operational Temperature	-	-40	-	+85	°C

**Table 8. Electrical Specifications**

**Absolute Maximum Ratings**

“Absolute maximum ratings” may cause permanent damage to the device and is a stress rating only, functional operation of the device under these conditions for extended periods may affect device reliability.

Symbol	Parameter	Max	Unit
$V_{DD}$	Supply voltage	6.2	V
$T_{op}$	Operational Temperature	-40~+85	°C
$T_{stg}$	Storage Temperature	-50~+150	°C
$ESD$	ESD Rating	2(HBM)	kV

**Table 9. Absolute Maximum Ratings**

**3. Programming Aspects of STR08CSH4**

Configuration and programming of STR08CSH4 implies flashing MCU code to STM32WLE5x. As for other STM32 MCUs, STM32WLE5x configuration, programming and debug can be done using ST-LINK and STM Tools/Platforms like STM32Cube IDE, STM32Cube Programmer and STM32CubeMX.

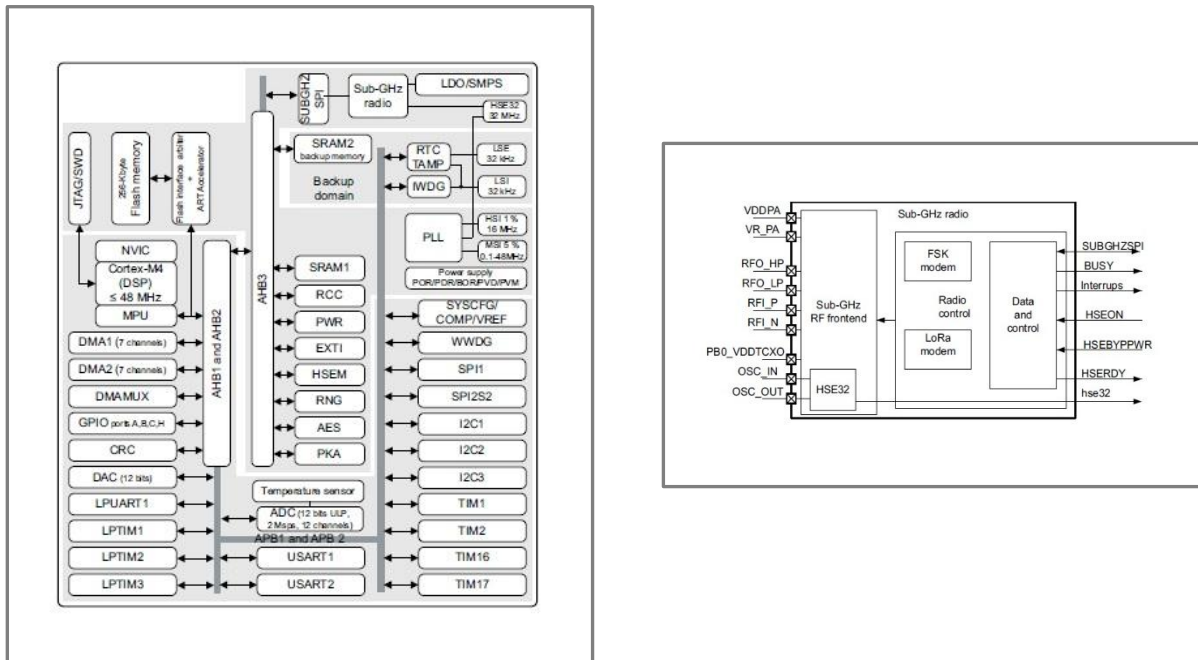

**Fig.4 STM32WLE5x Architecture and Sub-GHz Radio Block**

The STR08CSH4 is based on STM32WLE5CCU6 which has 256-Kbyte Flash memory, 64-Kbyte RAM, 20x32-bit backup register and bootloader supporting USART and SPI interfaces. The STM32WLE5CCU6 and consequently STR08CSH4 is also capable of OTA (over-the-air) firmware update.

Sub-GHz radio of STM32WLE5CCU6 is based on SX1262, therefore in following sections STM32WLE5x and SX1262 for radio part are used interchangeably.

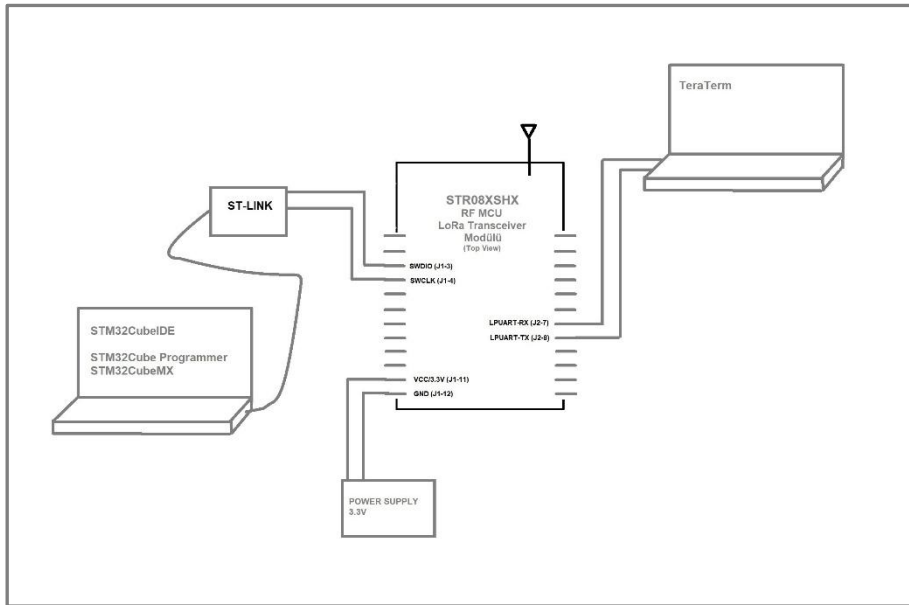

**Fig.5 STR08CSH4 Code Development/Porting/Testing**

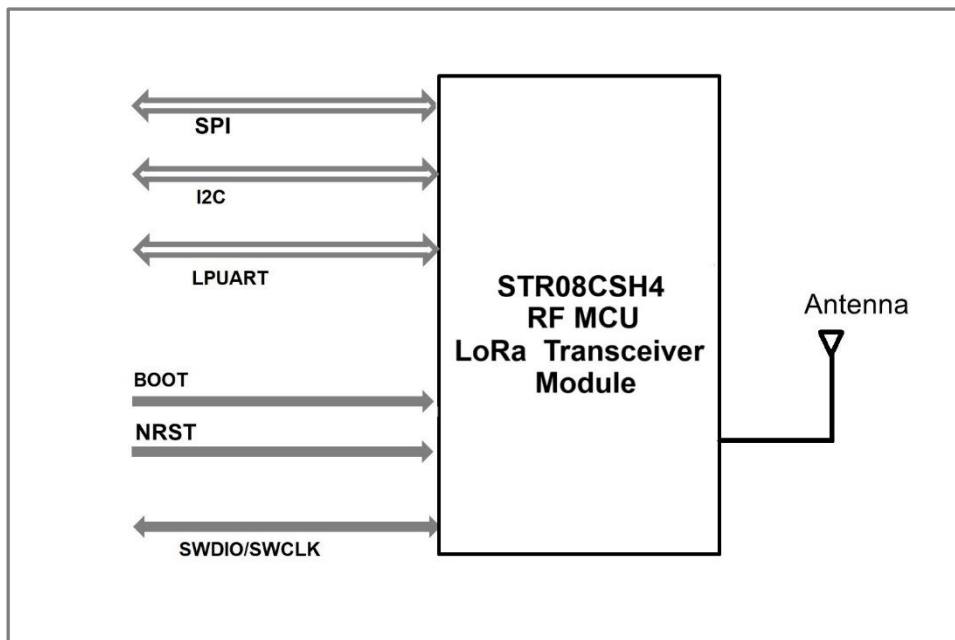

**Fig.6 Interfacing STR08CSH4 to external units**

## 4. Setting Modem, Transmitter & Receiver Parameters

The STR08CSH4 contains different modems capable of handling LoRa and FSK modulations. LoRa and FSK are associated with their own frame and modem.

The user specifies the modem and frame type by using the command *SetPacketType(...)*. This command specifies the frame used and consequently the modem implemented. This function is the first one to be called before going to Rx or Tx and before defining frequency, modulation and packet parameters.

### LoRa Modulation Technique and LoRa Parameters

The LoRa modem uses spread spectrum modulation and forward error correction techniques to increase the range and robustness of radio communication links compared to traditional FSK based modulation. An important facet of the LoRa modem is its increased immunity to interference. The LoRa modem is capable of co-channel GMSK rejection of up to 19dB. This immunity to interference permits the simple coexistence of LoRa modulated systems either in bands of heavy spectral usage or in hybrid communication networks that use LoRa to extend range when legacy modulation schemes fail.

#### Modulation Parameter

It is possible to optimize the LoRa modulation for a given application, access is given to the designer to choose four critical design parameters, each one permitting a trade-off between the link budget, immunity to interference, spectral occupancy and nominal data rate. These parameters are:

- Modulation BandWidth (BW\_L)
- Spreading Factor (SF)
- Coding Rate (CR)
- Low Data Rate Optimization (LDRO)

These parameters are set using the command *SetModulationParams(...)* which must be called after *SetPacketType(...)*.

LoRa has its own packet engine that supports the LoRa PHY. More details about LoRa Modem, LoRa Modulation Parameters, LoRa Packet Engine, LoRa Frame and LoRa Channel Activity Detection (CAD) can be found in STM32WLE5x Datasheet and SX1262 Datasheet.

### FSK/(G)FSK Modulation Technique and FSK/(G)FSK Parameters

The FSK modem can perform transmission and reception of 2-FSK modulated packets over a range of data rates from 0.6 kbps to 300 kbps. All parameters are set by using the command *SetModulationParams(...)*. This function should be called only after defining the protocol. The bitrate setting is referenced to the crystal oscillator and provides a precise means of setting the bit rate (or equivalently chip) rate of the radio.

The STR08CSH4 is designed for packet-based transmission. The packet controller block is responsible for assembly of the received data bit-stream into packets and their storage into the data buffer. It also performs the bit-stream decoding operations such as de-whitening & CRC-checks on the received bit-stream. On the transmit side, the packet handler can construct a packet and send it bit by bit to the modulator for transmission. It can whiten the payload and append the CRC-checksum to the end of the packet. The packet controller only works in half-duplex mode i.e. either in transmit or receive at a time. The packet controller is configured using the command *SetPacketParams(...)*

More details about FSK Modem, FSK Modulation Parameters, FSK Packet Format, FSK Frame and CRC use in FSK can be found in STM32WLE5x Datasheet and SX1262 Datasheet.

## RF Frequency, PA and TX Parameters

### RF Frequency Setting

The command *SetRfFrequency(...)* is used to set the frequency of the RF frequency mode. The LSB of Freq is equal to the PLL step giving:

$$Rf\ frequency = \frac{RfFreqxFXTAL}{2^{25}}$$

*SetRfFrequency(...)* defines the chip frequency in FS, TX and RX modes. In RX, the frequency is internally lowered to IF (250kHz by default).

Byte	0	1-4
Data from Host	Opcode=0x86	RFfreq(31:0)

**Table 10. RF Frequency Setting**

RF Frequency	RFfreq(31:0)
433.92MHz	0x1B1EC000
433MHz	0x1B100000
432MHz	0x1B000000
435MHz	0x1B300000
436MHz	0x1B400000

**Table 11. STR08CSH4 Typical Frequency Settings**

### PA Configuration

STR08CSH4 PA matching hardware is optimal for +20dBm output power, therefore a sample set of PA settings are provided here.

*paDutyCycle* controls the duty cycle (conduction angle). The maximum output power, the power consumption, and the harmonics will drastically change with *paDutyCycle*. Changing the *paDutyCycle* will affect the distribution of the power in the harmonics and should be selected to work in conjunction with a given matching network. For implemented matching network, *paDutyCycle* can be selected as 0x04.

*hpMax* selects the size of the PA. The maximum output power can be reduced by reducing the value of *hpMax*. For implemented matching network, *hpMax* can be selected as 0x06.

*deviceSel* is reserved and has always the value 0x00.

*paLut* is reserved and has always the value 0x01.

**PA Optimal Settings**

Byte	0	1	2	3	4
Data from Host	Opcode=0x98	paDutyCycle	hpMax	deviceSel	paLut

**Table 12. PA Settings**

Byte	0	1	2	3	4
Data from Host	Opcode=0x98	0x04	0x06	0x00	0x01

**Table 12B. STR08CSH4 Recommended PA Settings**

**TX Parameters**

*SetTxParams* command sets the TX output power by using the parameter *power* and the TX ramping time by using the parameter *RampTime*.

The power ramp time is defined by the parameter *RampTime* as defined in the following table

Byte	0	1	2
Data from Host	Opcode=0x8E	power	RampTime

**Table 13. TX Settings**

Byte	0	1	2
Data from Host	Opcode=0x8E	0x16	0x00

**Table 13B. STR08CSH4 Recommended TX Settings**

RampTime	Value	RampTime(us)
SET_RAMP_10U	0x00	10
SET_RAMP_20U	0x01	20
SET_RAMP_40U	0x02	40
SET_RAMP_80U	0x03	80
SET_RAMP_200U	0x04	200
SET_RAMP_800U	0x05	800
SET_RAMP_1700U	0x06	1700
SET_RAMP_3400U	0x07	3400

**Table 14. PA Ramp Time Settings**

## Data Buffer

The transceiver is equipped with a 256-byte RAM data buffer which is accessible in all modes except sleep mode. This RAM area is fully customizable by the user and allows access to either data for transmission or from the last packet reception.

### Data Buffer in Receive Mode

In receive mode *RxBaseAddr* specifies the buffer offset in memory at which the received packet payload data will be written. The buffer offset of the last byte written in receive mode is then stored in *RxDataPointer* which is initialized to the value of *RxBaseAddr* at the beginning of the reception.

The pointer to the first byte of the last packet received and the packet length can be read with the command *GetRxbufferStatus()*. In single mode, *RxDataPointer* is automatically initialized to *RxBaseAddr* each time the transceiver enters Rx mode. In continuous mode the pointer is incremented starting from the previous position.

### Data Buffer in Transmit Mode

Upon each transition to transmit mode *TxDataPointer* is initialized to *TxBaseAddr* and is incremented each time a byte is sent over the air. This operation stops once the number of bytes sent equals the payloadlength parameter as defined in the function *SetPacketParams(...)*.

### Using the Data Buffer

Both, *RxBaseAddr* and *TxBaseAddr* are set using the command *SetBufferBaseAddresses(...)*. By default *RxBaseAddr* and *TxBaseAddr* are initialized at address 0x00.

Due to the contiguous nature of the data buffer, the base addresses for Tx and Rx are fully configurable across the 256-byte memory area. Each pointer can be set independently anywhere within the buffer. To exploit the maximum data buffer size in transmit or receive mode, the whole data buffer can be used in each mode by setting the base addresses *TxBaseAddr* and *RxBaseAddr* at the bottom of the memory (0x00).

The data buffer is cleared when the device is put into Sleep mode (implying no access). The data is retained in all other modes of operation.

### Note:

All the received data will be written to the data buffer even if the CRC is invalid, permitting user-defined post processing of corrupted data. When receiving, if the packet size exceeds the buffer memory allocated for the Rx, it will overwrite the transmit portion of the data buffer.

More details about Data Buffer, Use of Data Buffer, Writing to and Reading from Buffer and Registers can be found in STM32WLE5x Datasheet and SX1262 Datasheet.

## 5. Module Aspects To Consider for User Application

STR08CSH4 433MHz MCU+RF LoRa Transceiver module is capable of using LDO Only or LDO+DC-DC mode of operation, and also uses an RF switch for TX and RX path switching in transmit and receive modes respectively. The user application code should contain proper settings for LDO Only or LDO+DC-DC mode of operation, RF switch use and proper calibration as detailed in following sections.

### LDO Only or LDO plus DC-DC Mode of Operation

In STR08CSH4 two forms of voltage regulation (DC-DC buck converter or linear LDO regulator) are available, the linear LDO regulator is always present in all modes but the transceiver will use DC-DC when selected. By default, only the LDO is used. *SetRegulatorMode(...)* function specifies if DC-DC or LDO is used for power regulation. The user can specify the use of DC-DC by using the command *SetRegulatorMode(...)*. This operation must be carried out in STDBY\_RC mode only. The regulation mode is defined by parameter *regModeParam*.

Byte	0	1
Data from Host	Opcode=0x96	regModeParam 0: Only LDO used for all modes 1: DC DC+LDO for STBY_XOSC,FS, RX and TX

**Table 15. Regulator Mode Selection**

**Note:**

**Hardware implementation of the STR08CSH4 allows using LDO only or LDO plus DC-DC mode of operations.**

### Image Calibration for 433MHz Frequency Band

Image calibration is done through the command *CalibrateImage(...)* for a given range of frequencies defined by the parameters *freq1* and *freq2*. Once performed, the calibration is valid for all frequencies between the two extremes used as parameters. Typically, the user can select the parameters *freq1* and *freq2* to cover any specific ISM band.

Byte	0	1	2
Data from Host	Opcode=0x98	freq1	freq2

**Table 16. Image Calibration for 433MHz frequency band**

By default, the image calibration is made in the band 902MHz-928MHz, therefore it should be repeated by requesting the device to perform a new image calibration for 433MHz frequency band by defining 430MHz-440MHz band.

Frequency Band	freq1	freq2
430MHz-440MHz	0x6B	0x6F

**Table 17. Image Calibration Frequencies**

**Use of RF Switch (controlled by PA9)**

STR08CSH4 uses an RF switch to activate/deactivate TX and RX paths in transmit and receive modes respectively, which is controlled by PA9 multifunction I/O pin of STM32WLE5x, therefore the user application should take use of PA9 GPIO into account detailed as follows.

PA9 will be at a logical 1 during Tx and at a logical 0 in any other mode, will be asserted high a few microseconds before the ramp-up of the PA and will be set to zero after the ramp-down of the PA.

Enable	Description
0x01	PA9 is selected to be used to control an RF switch. In this case: PA9 = 0 in SLEEP, STDBY_RX, STDBY_XOSC, FS and RX modes, PA9 = 1 in TX mode

**Table 18. PA9 as RF TX/RX Switch Control**

**Note:**

**For proper operation of the STR08CSH4, the PA9 GPIO should be configured as RF TX/RX switch accordingly.**

**Application Code Structure and Issuing Commands in the Right Order**

STR08CSH4 hardware is suitable for LDO Only or LDO+DC-DC mode of operation, includes an RF switch controlled by a dedicated GPIO PA9 of STM32WLE5x and a TCXO where the control voltage is supplied by PB0-VDD-TCXO pin of STM32WLE5x, therefore related IRQ/DIO mask settings, TCXO settings and RF switch settings should be configured, transmit and receive buffer base addresses should be defined and a calibration should be performed before radio configuration and operation.

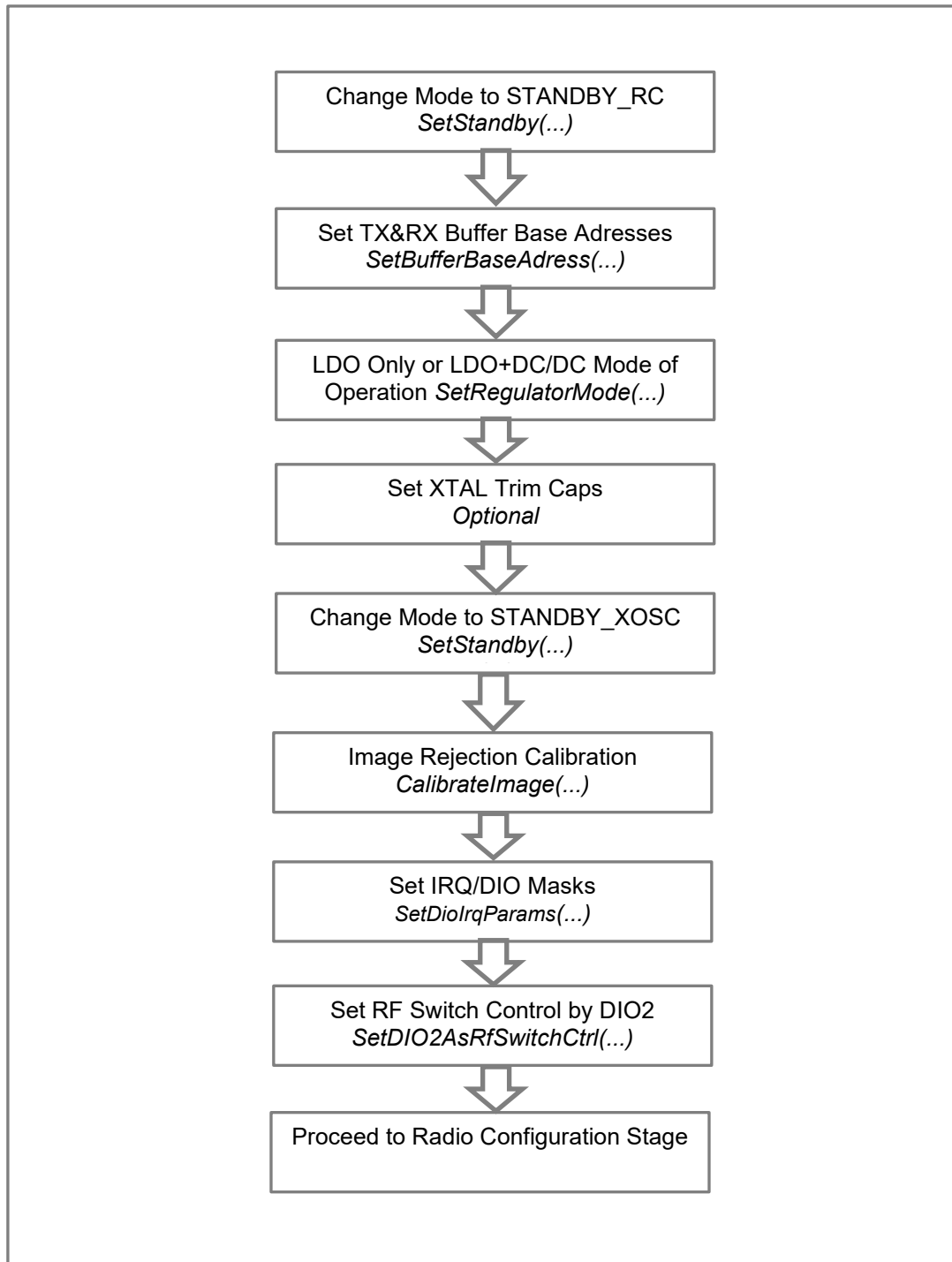

**Fig.7 Configuration and Settings - Standby Mode**

Most of the commands can be sent in any order except for the radio configuration commands which will set the radio in the proper operating mode.

It is mandatory to set the radio protocol using the command *SetPacketType(...)* as a first step before issuing any other radio configuration commands.

In a second step, the user should define the modulation parameter according to the chosen protocol with the command *SetModulationParams(...)*.

Finally, the user should then select the packet format with the command *SetPacketParams(...)*.

**Note:** If this order is not respected, the behavior of the device could be unexpected

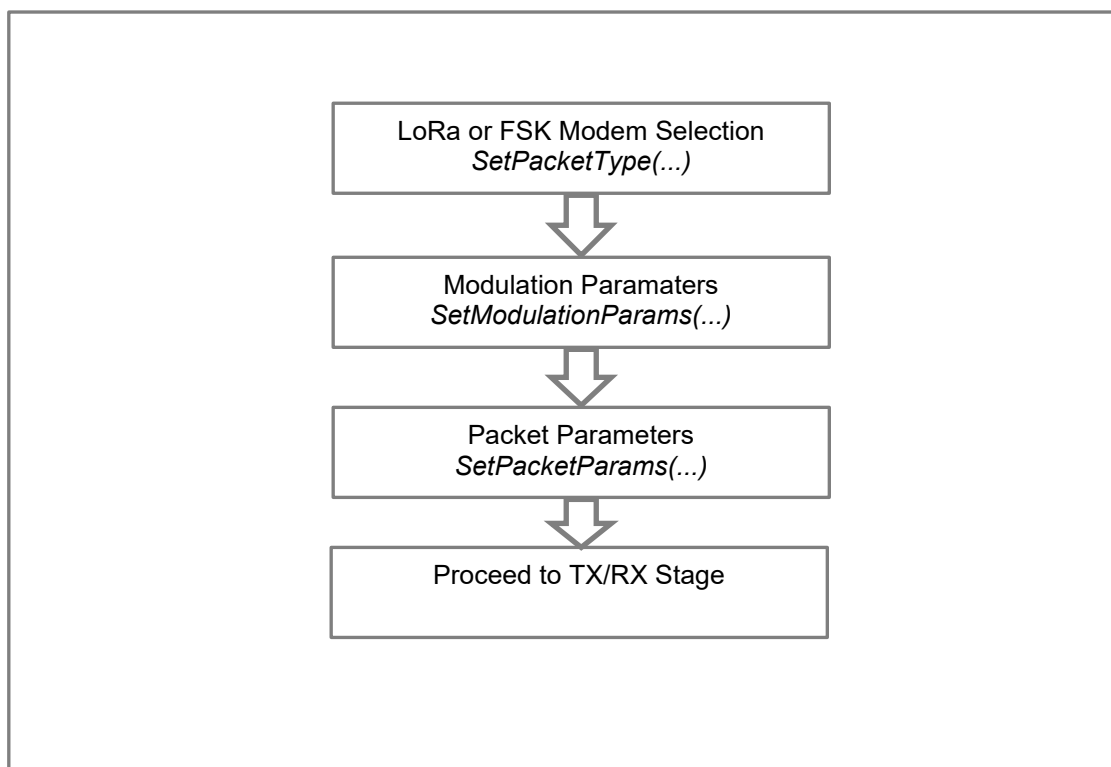

**Fig.8 Configuration and Settings - Modem Selection, Modulation and Packet Parameters**

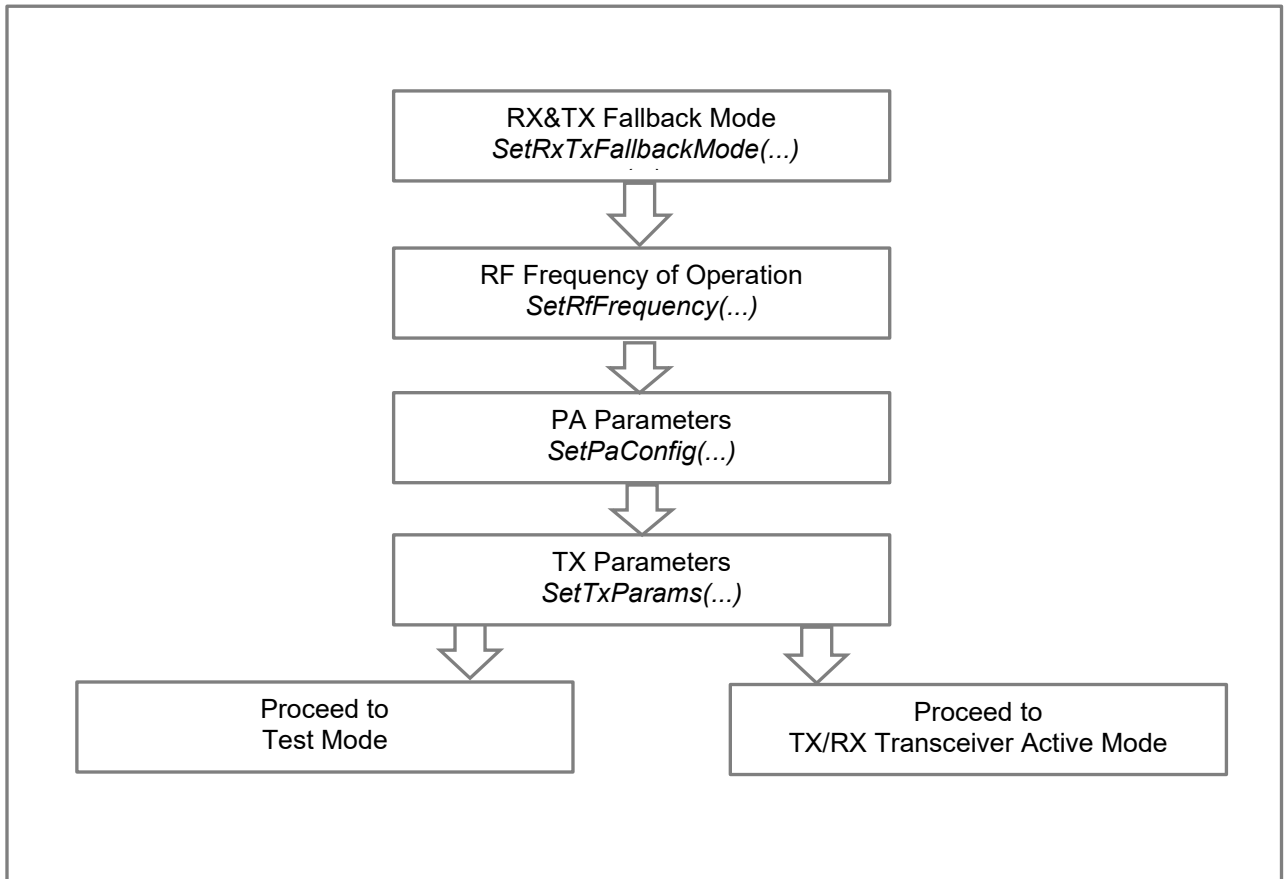

**Fig.9 Configuration and Settings – RF Frequency, PA and TX/RX Parameters**

## 6. Test Setup & Measurement Results

Figure.10 and Figure.11 below depict a simplified diagram used in Transmit Mode RF Output Power/Harmonic measurements and Receive Mode RF Sensitivity/SNR Measurements respectively. Typical measurement results (for TX Mode and RX Mode) are summarized in following tables, Table 22 to Table 27.

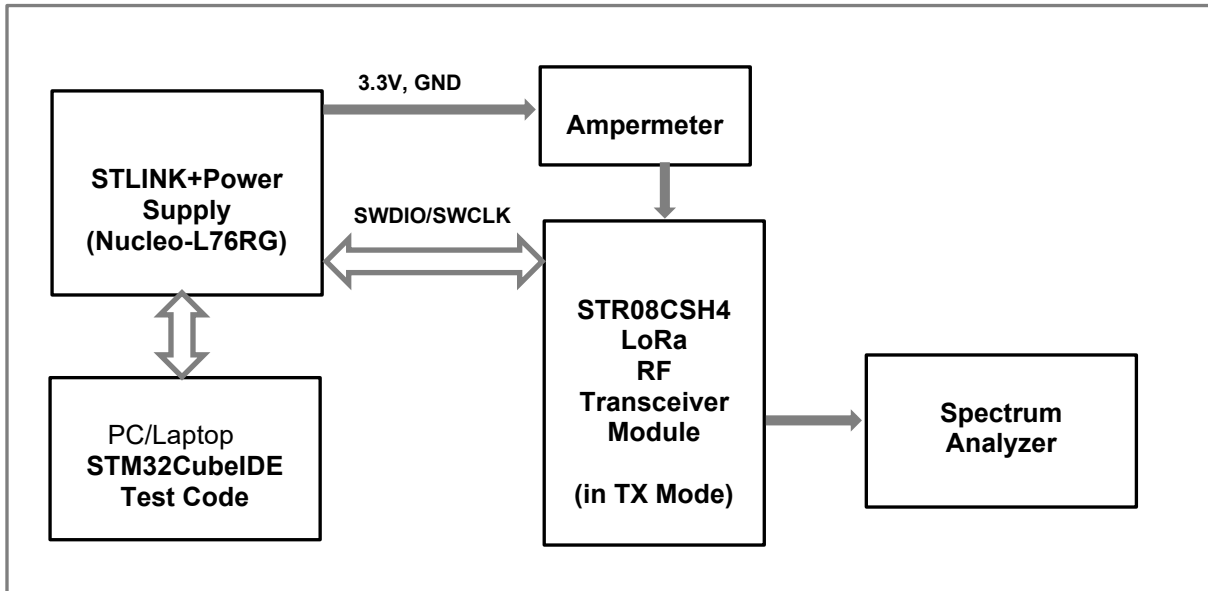

**Fig.10 STR08CSH4 Transmit Mode Test & Measurement Setup**

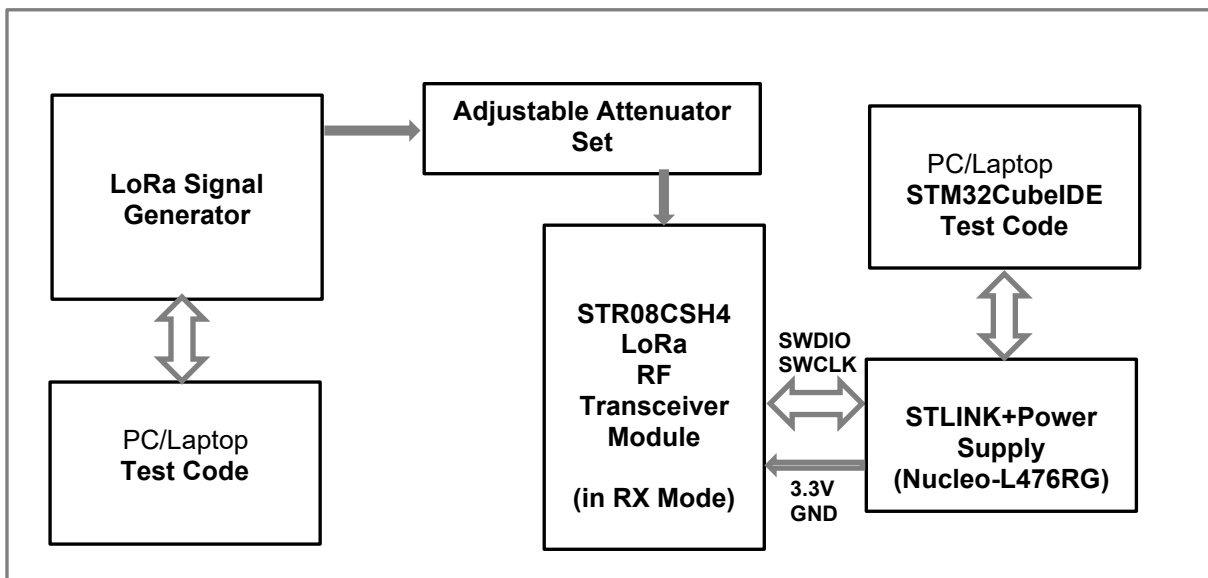

**Fig.11 STR08CSH4 Receive Mode Test & Measurement Setup**

## Transmit Mode - RF Output Power and Harmonics

STR08CSH4 is optimized for +20dBm RF output power (PA SET-4, paDutyCycle-0x04/hpMax-0x07), typical measurement results for other PA settings are provided below in Table 22, Table 23 shows programmable RF power output for selected TX Settings.

PA Settings vs RF Output Level, Harmonic Levels and Current						
Symbol	Description	PA SET-1 0x02/0x02	PA SET-2 0x02/0x03	PA SET-3 0x04/0x06	PA SET-4 0x04/0x07	Unit
$F_{op}$	Operational Frequency/Band	433	433	433	433	MHz
$P_{RFOUT}$	RF Output Power	+12.9	+14.6	+19.9	+20.4	dBm
$P_{RF-sat}$	Current	39	47	97	103	mA
$P_{HL2}$	2nd Harmonic Level	-52.7	-49.8	-46.2	-45.3	dBc
$P_{HL3}$	3rd Harmonic Level	-78.3	-74.1	-72.3	-71.4	dBc
$P_{HL4}$	4th Harmonic Level	-81.6	-79.3	-78.4	-76.7	dBc
$P_{HL5}$	5th Harmonic Level	-75.7	-74.2	-70.6	-70.2	dBc

**Table 22. PA Settings vs RF Output Level and Harmonics**

TX Settings vs RF Output Level, Frequency-433MHz		
PA SET-4, paDutyCycle-0x04/hpMax-0x07		
	TX Setting (Power/Ramp Time)	RF Output Power (dBm)
	0x16	+20.4
	0x13	+18.6
	0x10	+14.6
	0x0D	+11.6
	0x0A	+8.6
	0x07	+5.6
	0x04	+2.6
	0x01	-0.4
	0xFE	-3.4
	0xFB	-5.9
	0xF8	-9.4
	0xF7	-10.9

**Table 23. TX Settings vs RF Output Power**

**Receive Mode - RF Sensitivity and SNR**

Receive Mode RF Sensitivity/SNR Measurements are summarized through Table 24-27 for different SF and BW configurations.

<b>SF/BW&amp;RF Input Level vs RSSI&amp;SNR-----Sample from Measurements</b>			
<b>Frequency Band-433MHz , LoRa Parameters : SF-7, BW-125kHz</b>			
	<b>RF Input (TX CW Equivalent)</b>	<b>RSSI Instant/RSSI Packet (dBm)</b>	<b>SNR (dB)</b>
	-132dBm	0xD4/0xD2	0x1D
		-106/-105	7.25
	-129dBm	0xD2/0xCE	0x2C
		-105/-103	11.00
	-126dBm	0xC8/0xC6	0x29
		-100/-99	10.25
	-123dBm	0xC2/0xBE	0x2D
		-97/-95	11.25
	-120dBm	0xBC/0xBA	0x31
		-94/-93	12.25
	-110dBm	0xBA/0xB6	0x31
		-93/-91	12.25
	-100dBm	0xA4/0x9C	0x32
		-82/-78	12.5

**Table 27. RF Input vs RSSI & SNR (SF-7/BW-125kHz)**

## 7. Drawings

Figure.12 depicts a description of connector pinout and module dimensions for STR08CSH4. A detailed description of the individual pins can be found in Table 28 Connector and Pin Descriptions.

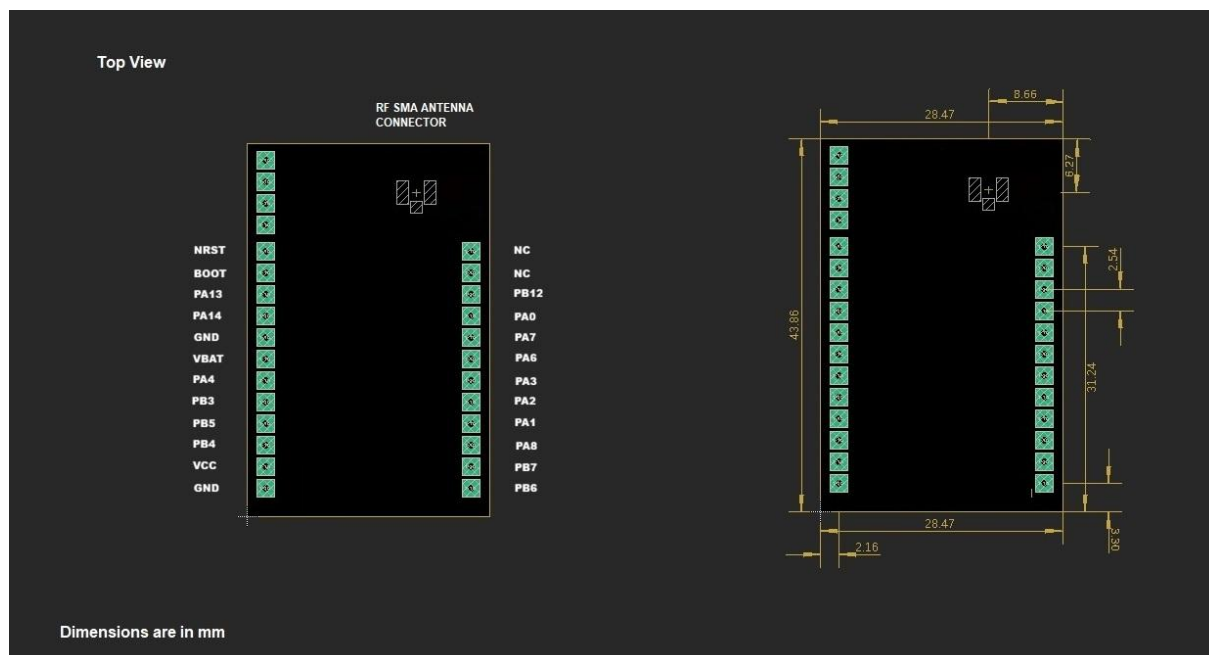

Fig.12 STR08CSH4 Pin and Size Diagram

CONNECTORS		
Pin No	Pin No	Use/(Possible Use)
CA	ANT	RF Output/Antenna
J1-Connector		
J1-1	NRST	Reset
J1-2	BOOT	Boot
J1-3	PA13	SWD Data
J1-4	PA14	SWD Clock
J1-5	GND	0V
J1-6	VBAT	+External battery (optional)
J1-7	PA4	GPIO (SPI chip select)
J1-8	PB3	GPIO (SPI clock)
J1-9	PB5	GPIO (SPI MOSI)
J1-10	PB4	GPIO (SPI MISO)
J1-11	VCC	3.3V (+Positive Supply)
J1-12	GND	0V
J2-Connector		
J2-1	NC	No Connection (NC/Internally GND)
J2-2	NC	No Connection (NC/Internally GND)
J2-3	PB12	GPIO_EXTI (External Interrupt)
J2-4	PA0	GPIO
J2-5	PA7	GPIO
J2-6	PA6	GPIO
J2-7	PA3	GPIO (LPUART RX)
J2-8	PA2	GPIO (LPUART TX)
J2-9	PA1	GPIO (ADC Analog Input)
J2-10	PA8	GPIO (Wakeup)
J2-11	PB7	GPIO (I2C Data)
J2-12	PB6	GPIO (I2C Clrok)

Table 28. Connector and Pin Descriptions (STR08CSH4)

## 8. Ordering Information

Order Code	Description
STR08CSH4	STR08CSH4 433MHz/+20dBm MCU+RF LoRa Transceiver Module (with U.FL RF Connector)

**Table 29. STR08CSH4 Ordering Info**

## Revision History

Date	Revision	Modifications
February 12,2026	1.1	Initial release
March 1,2026	1.2	Addition of Test Setup & Measurements Section, image updates and other minor syntax corrections

## References

- 1) STM32WLE5x Datasheet - <https://www.egn-elektronik.com.tr/EN/Datasheets/STM32WLE5x.pdf>
- 2) Semtech SX1262 Datasheet - <https://www.egn-elektronik.com.tr/EN/Datasheets/SX1262.pdf>
- 3) SX1262 Drivers - [https://github.com/Lora-net/sx126x\\_driver](https://github.com/Lora-net/sx126x_driver)
- 4) STM32Cube IDE - <https://www.st.com/en/development-tools/stm32cubeide.html>
- 5) STM32Cube WL Firmware Package <https://www.st.com/en/embedded-software/stm32cubewl.html>
- 6) STM32Cube Programmer - <https://www.st.com/en/development-tools/stm32cubeprog.html>
- 7) Driver for SX126X LoRa radio inside the STM32WLE5x - <https://github.com/Stroom/STM32WLE5x-SX126X-LoRaWAN>