

## NTR08 E Series 433MHz MP(+20dBm) RF LoRa Transceiver Modules

### Features - Radio

- 433MHz/868MHz ISM Frequency Band, LoRa and (G)FSK modem, SX1268 IC
- Data rate – Up to 300kbps for (G)FSK, Up to 62.5kbps for LoRa
- -146dBm Receiver Sensitivity (LoRa, SF=12, BW=10.4kHz)
- +20dBm RF Output Power (adjustable with 1dB step size)
- Buffer packet data, spectrum shaping, FEC-Forward Error Correction
- Low current consumption, 4.9mA in receive mode, 600nA in sleep mode
- Full radio configuration/control and modem/data parameters

### Other

- Power Supply : 1.8V~3.6V
- Operating Temperature : -40°C~+85°C
- Small profile : 43.10mmx28.60mm

MPN	Frequency	Connector	RF Shield
NTR08RSH4E	433MHz	SMA RF Connector	Yes
NTR08CSH4E	433MHz	U.FL RF Connector	Yes



# NTR08RSH4E

## 433MHz/+20dBm LoRa RF Transceiver Module

Datasheet

## **TABLE OF CONTENTS**

1.	NTR08RSH4E 433MHz/+20dBm LoRa RF Transceiver Module in Brief	3
2.	NTR08RSH4E Technical Data	7
3.	Interfacing NTR08RSH4E to Host Controller	8
4.	Operational Modes	10
5.	Setting Modem, Transmitter & Receiver Parameters	13
6.	Module Aspects to Consider for User Application	17
7.	Test Setup and Measurement Results	22
8.	Drawings	26
9.	Ordering Information	28

Revision History

References

## 1. NTR08RSH4E 433MHz/+20dBm LoRa RF Transceiver Module in Brief

NTR08RSH4E is a small size, compact, low power and easy to use 433MHz LoRa RF Transceiver module based on Semtech SX1268 Sub-GHz RF Transceiver IC. It supports both LoRa and G(FSK) modulations, provides radio configuration and control via the SPI interface and has up to -146dBm RF receiver sensitivity and up to +20dBm RF output power.

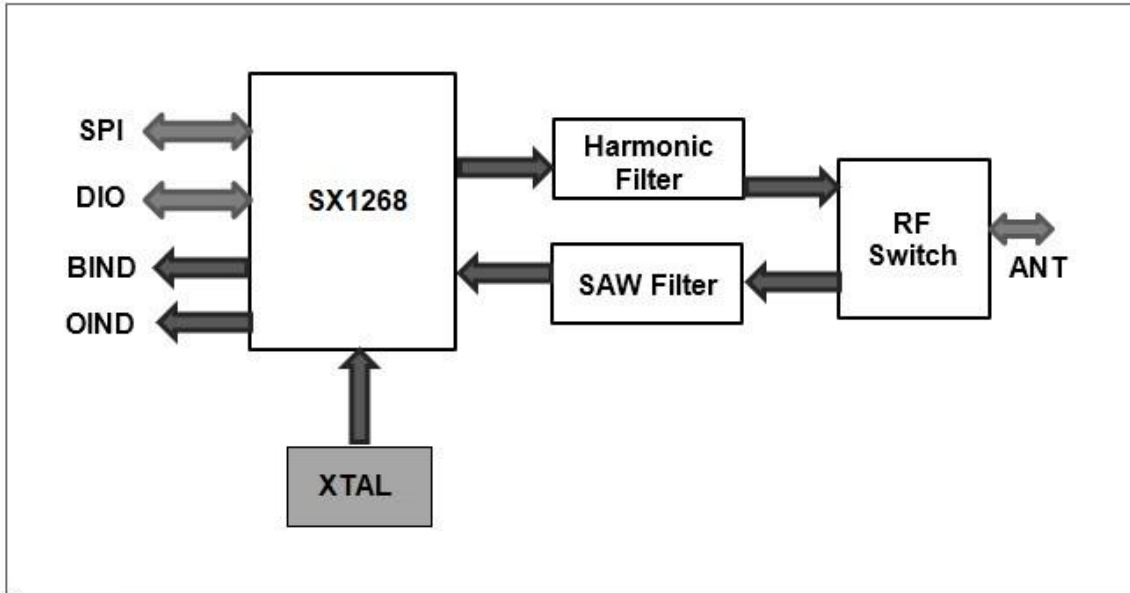

Fig.1 NTR08RSH4E functional blocks and interconnections

### Features

- Wide supply voltage range, 1.8V~3.6V
- Operating frequency 433MHz with LoRa and (G)FSK modems
- Up to 62.5kbps bit rate for LoRa and up to 300kps bit rate for (G)FSK
- Packet mode with data buffer, data whitening codec, FEC-Forward Error Correction
- -146dBm Receiver sensitivity, (@SF12 and LoRa BW-10.4kHz)
- +20dBm RF output power (programmable with 1dB steps)
- High frequency stability, long range and high performance
- Low power consumption,
  - 4.6mA, sleep mode <600nA (in receive mode)
  - 103mA (in transmit mode,@20dBm)
- Radio configuration and control via SPI interface
- Fully programmable frequency, modem, packet parameters and radio operational modes
- Small Size – 43.10mmx28.60mm

### Application Areas

- Low-cost consumer electronics applications, ISM band data communication
- Smart Building Automation
- Industrial Monitoring and Control
- Remote Control, Remote Keyless Entry, Remote AMR, Tag Reader
- Wireless Alarm and Security, Wireless Sensor Node



**Fig.2 NTR08RSH4E 433MHz/+20dBm RF LoRa Transceiver Module**

### LoRa Modulation Technique

The NTR08RSH4E uses Semtech’s patented LoRa modulation technique which combines spread spectrum modulation and forward error correction techniques to increase the range and robustness of radio communication links compared with traditional FSK or OOK based modulation. This high sensitivity, in contrast to conventional modulation techniques, permits an increase in link budget and increased immunity to in-band interference, combined with +20dBm RF output power yields industry leading link budget.

LoRa also provides significant advantages in both blocking and selectivity, solving the traditional design compromise between range, interference immunity and energy consumption. In LoRa mode the NTR08RSH4E offers ten bandwidth options as in table below.

Signal Bandwidth	0	1	2	3	4	5	6	7	8	9
BW_L (kHz)	7.81	10.42	15.63	20.83	31.25	41.67	62.5	125	250	500

**Table 1. NTR08RSH4E LoRa Mode BW Options**

The spread spectrum LoRa modulation is performed by representing each bit of payload information by multiple chips of information. The rate at which the spread information is sent is referred to as the symbol rate ( $R_s$ ), the ratio between the nominal symbol rate and chip rate is the spreading factor and represents the number of symbols sent per bit of information. The range of parameters which can be configured are given in the following tables.

Spreading Factor (SF)	5	6	7	8	9	10	11	12
Chips/Symbol	32	64	128	256	512	1024	2048	4096
SNR (dB)	-2.5	-5.0	-7.5	-10.0	-12.5	-15.0	-17.5	-20.0

**Table 2. NTR08RSH4E LoRa Mode Spreading Factors**

Note that the spreading factor must be known in advance on both transmit and receive sides of the radio link as different spreading factors are orthogonal to each other. Note also the resulting signal to noise ratio (SNR) required at the receiver input. It is the capability to receive signals with negative SNR that increases the sensitivity, so link budget and range, of the LoRa receiver.

To further improve the robustness of the radio link NTR08RSH4E provides cyclic error coding with different coding rates. By using this coding scheme forward error detection and correction can be applied.

### Differentiating Aspects of The NTR08RSH4E 433MHz LoRa RF Transceiver Module

One performance contributor of NTR08RSH4E is use of 433MHz SAW filter in RX path providing high selectivity which consequently providing high interference immunity and high sensitivity resulting in long range and exceptional bit error rate performance even in highly interfering environments with low SNR/SINR values, SAW filter characteristics are given below.

NTR08RSH4E is optimized for +20dBm RF power output, PA settings should be arranged according to Section 5. Setting Modem, Transmitter & Receiver Parameters as in Table12B, for other PA configuration settings matching is not optimum and the RF power output may be different from intended usually at a higher current consumption.

### 433MHz SAW Filter for High Selectivity and Interference Immunity

NTR08RSH4E includes a highly selective 433MHz SAW filter in RF front end in RX path for additional interference suppression. The characteristics of the SAW filter are given in Table 3 and Fig 4 below.

Parameter	Test Conditions	Min	Typical	Max	Unit
Center Frequency		-	433.92	-	MHz
3-dB Bandwidth		-	5	-	MHz
Attenuation	389 to 392MHz	42	54		dB
	411 to 414MHz	40	50		
	454 to 457MHz	40	51		
	475 to 478.5MHz	42	52		
	863 to 870MHz	41	35		

**Table 3. NTR08RSH4E SAW Filter Characteristics**

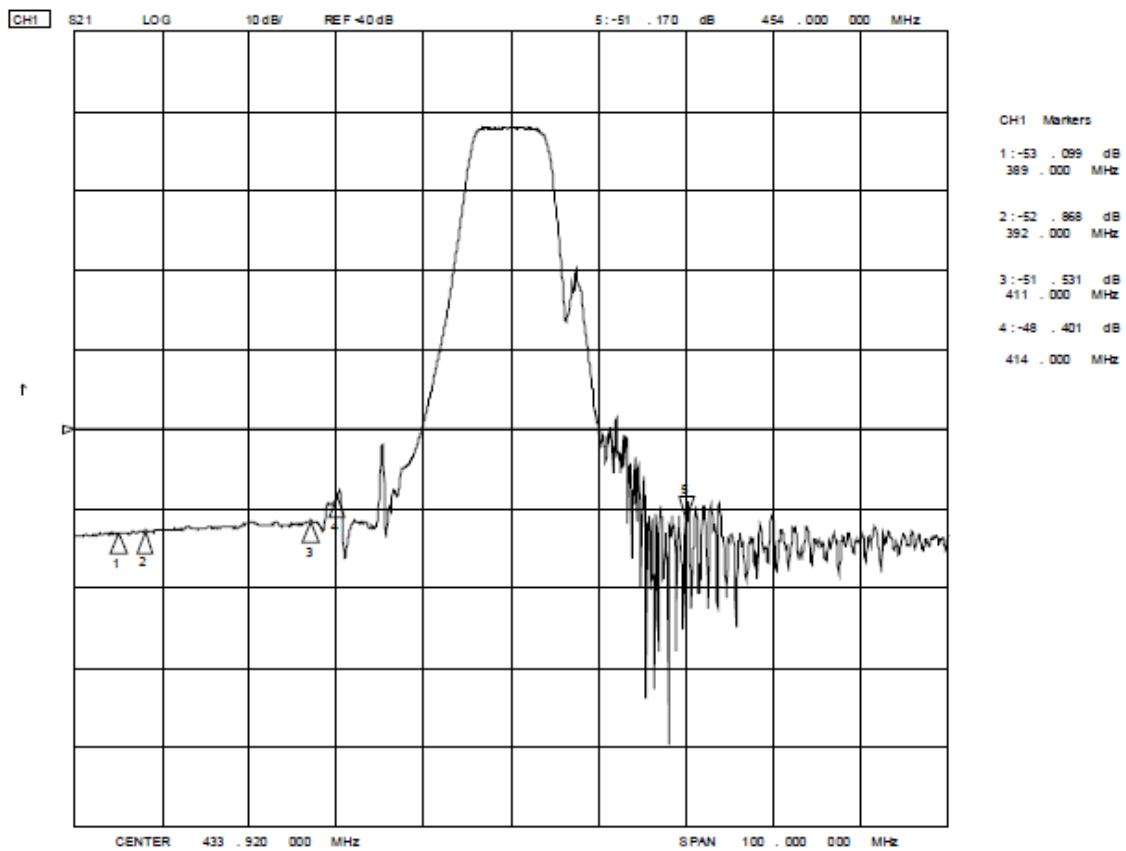

**Fig.4 NTR08RSH4E RF Front End SAW Filter Frequency Response**

Due to highly selective SAW filter use, severe performance degradations might be expected when operating frequency selected does not fit inside filter BW, therefore for optimal receiver performance an operating frequency in 432MHz-436MHz range should be selected.

## 2. NTR08RSH4E Technical Data

The tables below give the electrical specifications for the NTR08RSH4E 433MHz LoRa RF Transceiver Module operating with LoRa and FSK/(G)FSK modulation.

Symbol	Parameter	Test Conditions	Min	Typical	Max	Unit
$F_{op}$	Operational Frequency/Band	-	-	433	-	MHz
$S_{RFIN-FSK}$	Sensitivity-FSK	@4.8kbps, BW-20kHz	-	-117	-	dBm
		@0.6kbps, BW-4kHz	-	-122	-	
$S_{RFIN-LoRa}$	Sensitivity-LoRa	@SF12, BW-10.4kHz	-	-146	-	dBm
		@SF7, BW-500kHz	-	-116	-	
$CCR_{FSK}$	Co-channel Rejection-FSK			-9		dB
$CCR_{LoRa}$	Co-channel Rejection-LoRa	@SF12		19		dB
$ACR_{FSK}$	Adjacent-channel Rejection-FSK	+/-50kHz offset		45		dB
$ACR_{LoRa}$	Adjacent-channel Rejection-LoRa	+/-187kHz offset, SF-12		72		dB
$BI_{FSK}$	Blocking Immunity-FSK (4.8kbps, BW-20kHz)	+/-1MHz offset		68		dB
		+/-2MHz offset		70		
		+/-10MHz offset		80		
$BI_{LoRa}$	Blocking Immunity-LoRa (SF12, BW-125kHz)	+/-1MHz offset		88		dB
		+/-2MHz offset		90		
		+/-10MHz offset		99		
$IMA$	Image Attenuation-LoRa	with IQ calibration		54		dB
$IIP_3$	Third Order Intercept Point	Two tone test (1MHz/1.96MHz)	-	-5	-	dBm

**Table 4. RF Radio Receiver /Receive Mode Characteristics**

Symbol	Parameter	Test Conditions	Min	Typical	Max	Unit
$F_{op}$	Operational Frequency/Band	-	-	433	-	MHz
$P_{RFOUT}$	Maximum Output Power	-	-	+20	-	dBm
$P_{RF-sat}$	Power Change Step Size	Programmable	-	1	-	dB
$P_{STEP}$	RF Output Power Range	Programmable	-11	-	+20	dBm
$P_{RMP}$	RF Output Power Ramping Time	Programmable	10	-	3400	usec

**Table 5. RF Radio Transmitter/Transmit Mode Characteristics**

Symbol	Parameter	Test Conditions	Min	Typical	Max	Unit
$F_{step}$	Synthesizer Frequency Step Size	-	-	0.95	-	Hz
$SF_{LoRa}$	Spreading Factor-LoRa	Programmable	5	-	12	-
$BR_{LoRa}$	Bit Rate-LoRa	Programmable	0.018	-	62.5	kbps
$BW_{LoRa}$	Bandwidth-LoRa	Programmable	7.8	-	500	kHz
$BR_{FSK}$	Bit Rate-FSK	Programmable	0.6	-	300	kbps
$FDA_{FSK}$	Frequency Deviation-FSK	Programmable	0.6	-	200	kHz

**Table 6. LoRa/FSK Modem and Frequency Synthesizer Characteristics**

Symbol	Parameter	Test Conditions	Min	Typical	Max	Unit
$V_{IH}$	Input High Voltage		0.7*VCC	-	VCC+0.3	V
$V_{IL}$	Input Low Voltage		-0.3	-	0.3*VCC	V
$V_{OH}$	Output High Voltage		0.9*VCC	-	VCC	V
$V_{OL}$	Output Low Voltage		0	-	0.1*VCC	V
$V_{IL\_NRST}$	Input High Voltage for NRST		-0.3	-	0.2*VCC	V

**Table 7. Digital I/O Characteristics**

Symbol	Parameter	Test Conditions	Min	Typical	Max	Unit
$V_{cc}$	Supply Voltage	-	1.8	3.3	3.6	V
$I_{dd\_SLP}$	Current–Sleep mode		-	600	-	nA
$I_{dd\_TX}$	Current–Transmit mode		-	103	-	mA
$I_{dd\_RX}$	Current–Receive mode		-	4.6	-	mA
$T_{op}$	Operational Temperature	-	-40	-	+85	°C

**Table 8. Electrical Specifications**

### Absolute Maximum Ratings

“Absolute maximum ratings” may cause permanent damage to the device and is a stress rating only, functional operation of the device under these conditions for extended periods may affect device reliability.

Symbol	Parameter	Max	Unit
$V_{DD}$	Supply voltage	3.6	V
$T_{op}$	Operational Temperature	-40~+85	°C
$T_{stg}$	Storage Temperature	-50~+150	°C
$ESD$	ESD Rating	2(HBM)	kV

**Table 9. Absolute Maximum Ratings**

## 3. Interfacing NTR08RSH4E to Host Controller

The NTR08RSH4E is controlled via a serial SPI interface and a general-purpose input/output (DIO1) used for IRQ. The BIND (Busy Indicator) line is mandatory to ensure the host controller is ready to accept the commands. BIND is used as a busy signal indicating that the module is ready for new command only if this signal is low. When BIND is high, the host controller must wait until it goes down again before sending another command. Through SPI the application sends commands to the internal chip or accesses directly the data memory space.

### Reset

A complete “factory reset” of the SX1268 in module can be issued on request by toggling pin NRST of the NTR08RSH4E. It will be automatically followed by the standard calibration procedure and any previous context will be lost. The pin should be held low for more typically 100µs for the Reset to happen.

### SPI Interface

The SPI interface gives access to the configuration register via a synchronous full-duplex protocol corresponding to CPOL= 0 and CPHA = 0 and NTR08RSH4E behaves as slave. An address byte followed by a data byte is sent for a write access whereas an address byte is sent, and a read byte is received for the read access. The NSS pin goes low at the beginning of the frame and goes high after the data byte. MOSI is generated by the master on the falling edge of SCK and is sampled by the slave (i.e. this SPI interface) on the rising edge of SCK. MISO is generated by the slave on the falling edge of SCK. A transfer is always started by the NSS pin going low. MISO is high impedance when NSS is high. The SPI runs on the external SCK clock provided by the master.

### SPI Timing When the Transceiver Leaves Sleep Mode

In Sleep mode and during the initialization phase, the busy signal mapped on BIND pin, is set high indicating to the host that the module is not able to accept a new command. Once the module is in STDBY\_RC mode, the busy signal goes low, and the host can start sending a command. This is also true for startup at battery insertion or after a hard reset.

One way for the module to leave Sleep mode is to wait for a falling edge of NSS. At falling edge, all necessary internal regulators are switched On; the module starts initialization before being able to accept first SPI command. This means that the delay between the falling edge of NSS and the first rising edge of SCK must take into account the wake-up sequence and the initialization.

Through the SPI interface, the host can issue commands to the module or access the data memory space to directly retrieve or write data. In normal operation, a reduced number of direct data write operations is required except when accessing the data buffer. The user interacts with the circuit through an API (instruction set).

The NTR08RSH4E module BIND pin indicates the status of the module and its ability (or not) to receive another command while internal processing occurs. Prior to executing one of the generic functions, it is thus necessary to check the status of BIND to make sure the module is in a state where it can process another function.

**Command Structure**

In case of a command that does not require any parameter, the host sends only the opcode (1 byte). In case of a command which requires one or several parameters, the opcode byte is followed immediately by parameter bytes with the NSS rising edge terminating the command.

**Transaction Termination**

The host terminates an SPI transaction with the rising NSS signal; the host does not explicitly send the command length as a parameter. The host must not raise NSS within the bytes of a transaction. If a transaction sends a command requiring parameters, all the parameters must be sent before rising NSS, if not the module will take some unknown value for the missing parameters.

More details about SPI interface, command structures, registers and FIFO can be found in SX1268 Datasheet.

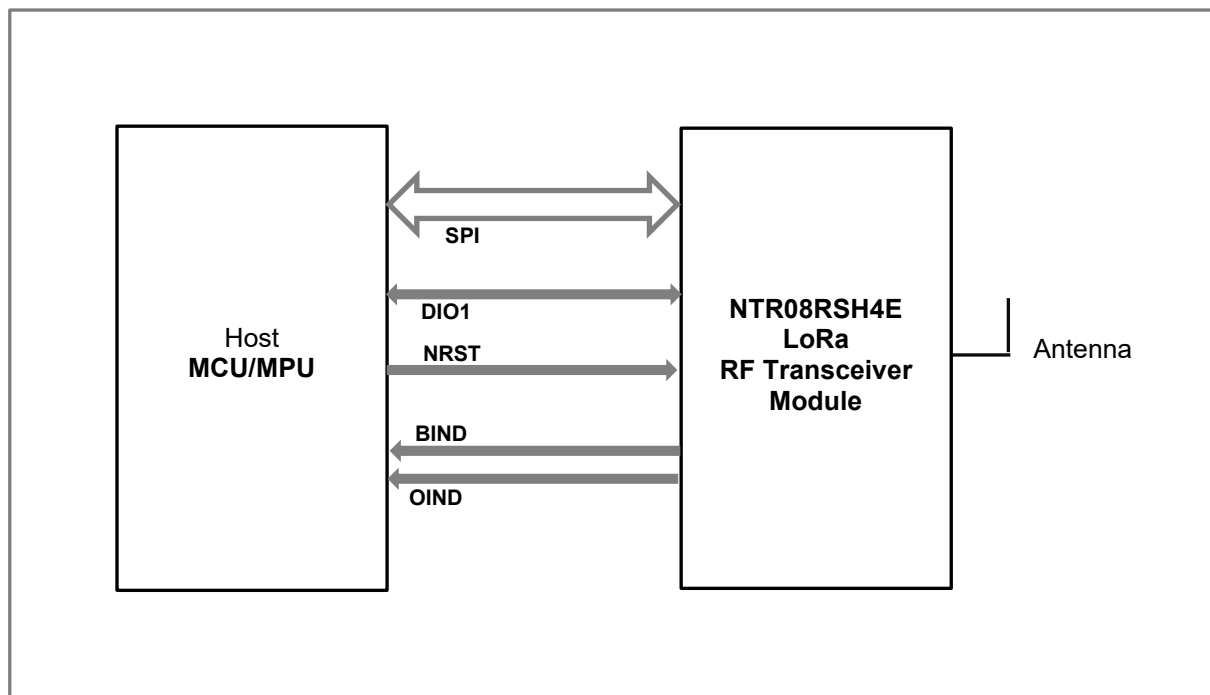

**Fig.5 Interfacing NTR08RSH4E to MCU/MPU**

## 4. Operational Modes

The NTR08RSH4E features six operating modes based on operating modes of SX1268, each operating mode is explained in the following table and details of operational modes can be found in SX1268 Datasheet.

Operation Mode	Enabled Blocks
SLEEP	Optional registers, backup regulator, RC64k oscillator, data RAM
STANDBY_RC	Top regulator (LDO), RC13M oscillator
STANDBY_XOSC	Top regulator (DC-DC or LDO), XOSC
FS	All of the above + Frequency synthesizer at Tx frequency
TX	Frequency synthesizer and transmitter, Modem
RX	Frequency synthesizer and receiver, Modem

**Table 10. NTR08RSH4E Operational Modes**

### Startup

At power-up or after a reset, the module goes into STARTUP state, the control being done by the sleep state machine operating at the battery voltage. The BIND pin is set to high indicating that the module is busy and cannot accept a command. When the digital voltage and RC clock become available, SX1268 can boot up and the CPU takes control. At this stage the BIND line goes down and the device is ready to accept commands.

### Calibration

The calibration procedure is automatically called in case of POR or via the calibration command. Parameters can be added to the calibrate command to identify which section of calibration should be repeated. The following blocks can be calibrated:

- RC64k using the 32 MHz XTAL as reference
- RC13M using the 32 MHz XTAL as reference
- PLL to select the proper VCO frequency and division ratio for any RF frequency
- RX ADC
- Image (RX mode with defined tone)

Once the calibration is finished, the chip enters STDBY\_RC mode.

### Sleep Mode

In this mode, most of the radio internal blocks are powered down or in low power mode and optionally the RC64k clock and the timer are running. The chip may enter this mode from STDBY\_RC and can leave the SLEEP mode if one of the following events occurs:

- NSS pin goes low in any case
- RTC timer generates an End-Of-Count (corresponding to Listen mode)

When the radio is in Sleep mode, the BIND pin is held high.

### Standby (STDBY) Mode

In standby mode the host should configure the module before going to RX or TX modes. By default in this state, the system is clocked by the 13 MHz RC oscillator to reduce power consumption (in all other modes except SLEEP the XTAL is turned ON).

However, if the application is time critical, the XOSC block can be turned or left ON. XOSC or RC13M selection in standby mode is determined by mode parameter in the command *SetStandby(...)*.

The mode where only RC13M is used is called STDBY\_RC and the one with XOSC ON is called STDBY\_XOSC.

### Frequency Synthesis (FS) Mode

In FS mode, PLL and related regulators are switched ON. The BIND goes low as soon as the PLL is locked or timed out. For debugging purposes the chip may be requested to remain in this mode by using the *SetFs()* command

### Receive (RX) Mode

In RX mode, the RF front-end, RX ADC and the selected modem (LoRa or FSK) are turned ON. In RX mode the circuit can operate in different sub-modes:

- Continuous mode: the device remains in RX mode and waits for incoming packet reception until the host requests a different mode,
- Single mode: the device returns automatically to STDBY\_RC mode after packet reception,
- Single mode with timeout: the device returns automatically to STDBY\_RC mode after packet reception or after the selected timeout,
- Listen mode: the device alternate between Sleep and Rx mode until an IRQ is triggered.

In RX mode, BIND will go low as soon as the RX is enabled and ready to receive data.

The NTR08RSH4E can operate in Rx Boosted gain setup or in Rx power saving gain setup. In the Rx power saving gain, the radio will consume less power at a small cost in sensitivity. In Rx Boosted gain, the radio will consume more power to improve the sensitivity.

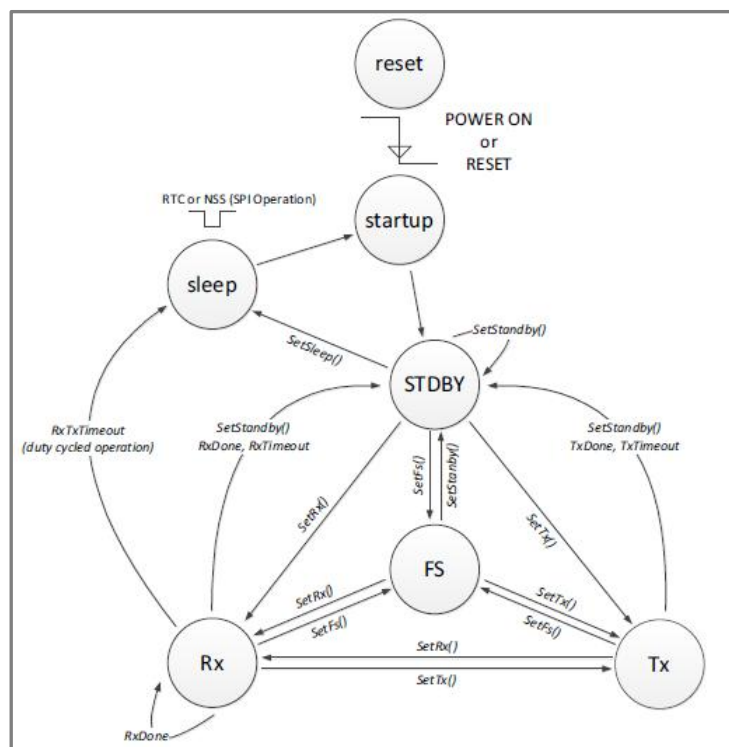

**Fig.6 NTR08RSH4E Operational Modes**

**Transmit (TX) Mode**

In TX mode, after enabling and ramping-up the Power Amplifier (PA), the contents of the data buffer are transmitted. The circuit can operate in different sub-modes: single mode or single with timeout mode.

In TX mode, BIND will go low as soon as the PA has ramped-up and transmission of preamble starts.

**PA Ramping**

The ramping of the PA can be selected while setting the output power by using the command *SetTxParams(...)*. The PA ramp time can be selected to go from 10us up to 3.4ms.

## 5. Setting Modem, Transmitter & Receiver Parameters

The SX1268 and consequently NTR08RSH4E contains different modems capable of handling LoRa and FSK modulations. LoRa and FSK are associated with their own frame and modem.

The user specifies the modem and frame type by using the command *SetPacketType(...)*. This command specifies the frame used and consequently the modem implemented. This function is the first one to be called before going to Rx or Tx and before defining frequency, modulation and packet parameters.

### LoRa Modulation Technique and LoRa Parameters

The LoRa modem uses spread spectrum modulation and forward error correction techniques to increase the range and robustness of radio communication links compared to traditional FSK based modulation. An important facet of the LoRa modem is its increased immunity to interference. The LoRa modem is capable of co-channel GMSK rejection of up to 19 dB. This immunity to interference permits the simple coexistence of LoRa modulated systems either in bands of heavy spectral usage or in hybrid communication networks that use LoRa to extend range when legacy modulation schemes fail.

#### Modulation Parameter

It is possible to optimize the LoRa modulation for a given application, access is given to the designer to four critical design parameters, each one permitting a trade-off between the link budget, immunity to interference, spectral occupancy and nominal data rate. These parameters are:

- Modulation BandWidth (BW\_L)
- Spreading Factor (SF)
- Coding Rate (CR)
- Low Data Rate Optimization (LDRO)

These parameters are set using the command *SetModulationParams(...)* which must be called after *SetPacketType(...)*.

LoRa has its own packet engine that supports the LoRa PHY. More details about LoRa Modem, LoRa Modulation Parameters, LoRa Packet Engine, LoRa Frame and LoRa Channel Activity Detection (CAD) can be found in SX1268 Datasheet.

### FSK/(G)FSK Modulation Technique and FSK/(G)FSK Parameters

The FSK modem can perform transmission and reception of 2-FSK modulated packets over a range of data rates from 0.6 kbps to 300 kbps. All parameters are set by using the command *SetModulationParams(...)*. This function should be called only after defining the protocol. The bitrate setting is referenced to the crystal oscillator and provides a precise means of setting the bit rate (or equivalently chip) rate of the radio.

The SX1268 and consequently NTR08RSH4E is designed for packet-based transmission. The packet controller block is responsible for assembly of the received data bit-stream into packets and their storage into the data buffer. It also performs the bit-stream decoding operations such as de-whitening & CRC-checks on the received bit-stream. On the transmit side, the packet handler can construct a packet and send it bit by bit to the modulator for transmission. It can whiten the payload and append the CRC-checksum to the end of the packet. The packet controller only works in half-duplex mode i.e. either in transmit or receive at a time. The packet controller is configured using the command *SetPacketParams(...)*

More details about FSK Modem, FSK Modulation Parameters, FSK Packet Format, FSK Frame and CRC use in FSK can be found in SX1268 Datasheet.

## RF Frequency, PA and TX Parameters

### RF Frequency Setting

The command *SetRfFrequency(...)* is used to set the frequency of the RF frequency mode. The LSB of Freq is equal to the PLL step giving:

$$Rf\text{frequency} = \frac{Rf\text{Freq}x\text{FXTAL}}{2^{25}}$$

*SetRfFrequency(...)* defines the chip frequency in FS, TX and RX modes. In RX, the frequency is internally lowered to IF (250kHz by default).

Byte	0	1-4
Data from Host	Opcode=0x86	RFfreq(31:0)

**Table 11. RF Frequency Setting**

RF Frequency	RFfreq(31:0)
433.92MHz	0x1B1EC000
433MHz	0x1B100000
432MHz	0x1B000000
435MHz	0x1B300000
436MHz	0x1B400000

**Table 11B. NTR08RSH4E Typical Frequency Settings**

### PA Configuration

NTR08RSH4E PA matching hardware is optimal for +20dBm output power, therefore a sample set of PA settings are provided here.

*paDutyCycle* controls the duty cycle (conduction angle). The maximum output power, the power consumption, and the harmonics will drastically change with *paDutyCycle*. Changing the *paDutyCycle* will affect the distribution of the power in the harmonics and should be selected to work in conjunction with a given matching network. For implemented matching network, *paDutyCycle* can be selected as 0x04.

*hpMax* selects the size of the PA. The maximum output power can be reduced by reducing the value of *hpMax*. For implemented matching network, *hpMax* can be selected as 0x06.

*deviceSel* is reserved and has always the value 0x00.

*paLut* is reserved and has always the value 0x01.

## PA Optimal Settings

Byte	0	1	2	3	4
Data from Host	Opcode=0x98	paDutyCycle	hpMax	deviceSel	paLut

**Table 12. PA Settings**

Byte	0	1	2	3	4
Data from Host	Opcode=0x98	0x04	0x06	0x00	0x01

**Table 12B. NTR08RSH4E Recommended PA Settings**

## TX Parameters

*SetTxParams* command sets the TX output power by using the parameter *power* and the TX ramping time by using the parameter *RampTime*.

The power ramp time is defined by the parameter *RampTime* as defined in the following table

Byte	0	1	2
Data from Host	Opcode=0x8E	power	RampTime

**Table 13. TX Settings**

Byte	0	1	2
Data from Host	Opcode=0x8E	0x16	0x00

**Table 13B. NTR08RSH4E Recommended TX Settings**

RampTime	Value	RampTime(us)
SET_RAMP_10U	0x00	10
SET_RAMP_20U	0x01	20
SET_RAMP_40U	0x02	40
SET_RAMP_80U	0x03	80
SET_RAMP_200U	0x04	200
SET_RAMP_800U	0x05	800
SET_RAMP_1700U	0x06	1700
SET_RAMP_3400U	0x07	3400

**Table 14. PA Ramp Time Settings**

## Data Buffer

The transceiver is equipped with a 256-byte RAM data buffer which is accessible in all modes except sleep mode. This RAM area is fully customizable by the user and allows access to either data for transmission or from the last packet reception.

### Data Buffer in Receive Mode

In receive mode *RxBaseAddr* specifies the buffer offset in memory at which the received packet payload data will be written. The buffer offset of the last byte written in receive mode is then stored in *RxDataPointer* which is initialized to the value of *RxBaseAddr* at the beginning of the reception.

The pointer to the first byte of the last packet received and the packet length can be read with the command *GetRxbufferStatus()*. In single mode, *RxDataPointer* is automatically initialized to *RxBaseAddr* each time the transceiver enters Rx mode. In continuous mode the pointer is incremented starting from the previous position.

### Data Buffer in Transmit Mode

Upon each transition to transmit mode *TxDataPointer* is initialized to *TxBaseAddr* and is incremented each time a byte is sent over the air. This operation stops once the number of bytes sent equals the *payloadlength* parameter as defined in the function *SetPacketParams(...)*.

### Using the Data Buffer

Both, *RxBaseAddr* and *TxBaseAddr* are set using the command *SetBufferBaseAddresses(...)*. By default *RxBaseAddr* and *TxBaseAddr* are initialized at address 0x00.

Due to the contiguous nature of the data buffer, the base addresses for Tx and Rx are fully configurable across the 256-byte memory area. Each pointer can be set independently anywhere within the buffer. To exploit the maximum data buffer size in transmit or receive mode, the whole data buffer can be used in each mode by setting the base addresses *TxBaseAddr* and *RxBaseAddr* at the bottom of the memory (0x00).

The data buffer is cleared when the device is put into Sleep mode (implying no access). The data is retained in all other modes of operation.

### Note:

All the received data will be written to the data buffer even if the CRC is invalid, permitting user-defined post processing of corrupted data. When receiving, if the packet size exceeds the buffer memory allocated for the Rx, it will overwrite the transmit portion of the data buffer.

More details about Data Buffer, Use of Data Buffer, Writing to and Reading from Buffer and Registers can be found in SX1268 Datasheet.

## 6. Module Aspects To Consider for User Application

NTR08RSH4E LoRa RF Transceiver module uses low ppm XTAL for high frequency stability and also an RF switch for TX and RX path switching in transmit and receive modes respectively. The user application code should contain proper settings for DC-DC or LDO Only mode of regulator operation, XTAL use, RF switch use and proper calibration as detailed in following sections.

### LDO Only or DC-DC Mode of Operation

In SX1268 two forms of voltage regulation (DC-DC buck converter or linear LDO regulator) are available, the linear LDO regulator is always present in all modes but the transceiver will use DC-DC when selected. By default, only the LDO is used. *SetRegulatorMode(...)* function specifies if DC-DC or LDO is used for power regulation. The user can specify the use of DC-DC by using the command *SetRegulatorMode(...)*. This operation must be carried out in STDBY\_RC mode only. The regulation mode is defined by parameter *regModeParam*.

Byte	0	1
Data from Host	Opcode=0x96	regModeParam 0: Only LDO used for all modes 1: DC DC+LDO for STBY_XOSC,FS, RX and TX

Table 15. Regulator Mode Selection

**Hardware implementation of the NTR08XXH8 allows using LDO only or LDO plus DC-DC mode of operations.**

### Image Calibration for 433MHz Frequency Band

Image calibration is done through the command *CalibrateImage(...)* for a given range of frequencies defined by the parameters *freq1* and *freq2*. Once performed, the calibration is valid for all frequencies between the two extremes used as parameters. Typically, the user can select the parameters *freq1* and *freq2* to cover any specific ISM band.

Byte	0	1	2
Data from Host	Opcode=0x98	freq1	freq2

Table 18. Image Calibration for 433MHz frequency band

By default, the image calibration is made in the band 470MHz-510MHz, therefore it should be repeated by requesting the device to perform a new image calibration for 433MHz frequency band by defining 430MHz-440MHz band.

Frequency Band	freq1	freq2
430MHz-440MHz	0x6B	0x6F

Table 19. Image Calibration Frequencies

### Use of RF Switch (controlled by DIO2)

NTR08RSH4E uses an RF switch to activate/deactivate TX and RX paths in transmit and receive modes respectively, and RF switch used is controlled by DIO2 multifunction I/O pin of SX1268, therefore the user application should take use of DIO2 into account detailed as follows.

DIO2 should be configured to drive the RF switch through the use of the command *SetDio2AsRfSwitchCtrl(...)*. In this mode, DIO2 will be at a logical 1 during Tx and at a logical 0 in any other mode. DIO2 will be asserted high a few microseconds before the ramp-up of the PA and will be set to zero after the ramp-down of the PA.

Byte	0	1
Data from Host	Opcode=0x9D	enable

**Table 20. DIO2 RF Switch Configuration**

The enable byte definition is given as follows:

Enable	Description
0x00	DIO2 is free to be used as an IRQ
0x01	DIO2 is selected to be used to control an RF switch. In this case: DIO2 = 0 in SLEEP, STDBY_RX, STDBY_XOSC, FS and RX modes, DIO2 = 1 in TX mode

**Table 21. DIO2 Options**

**Note:**

**For proper operation of the NTR08RSH4E, the DIO2 should be configured accordingly by enabling with 0x01 parameter.**

**Application Code Structure and Issuing Commands in the Right Order**

NTR08RSH4E hardware is suitable for LDO only or DC-DC regulator mode of operation and includes an RF switch controlled by DIO2 of SX1268, therefore related IRQ/DIO mask settings, RF switch settings should be configured, transmit and receive buffer base addresses should be defined and a calibration should be performed before radio configuration and operation.

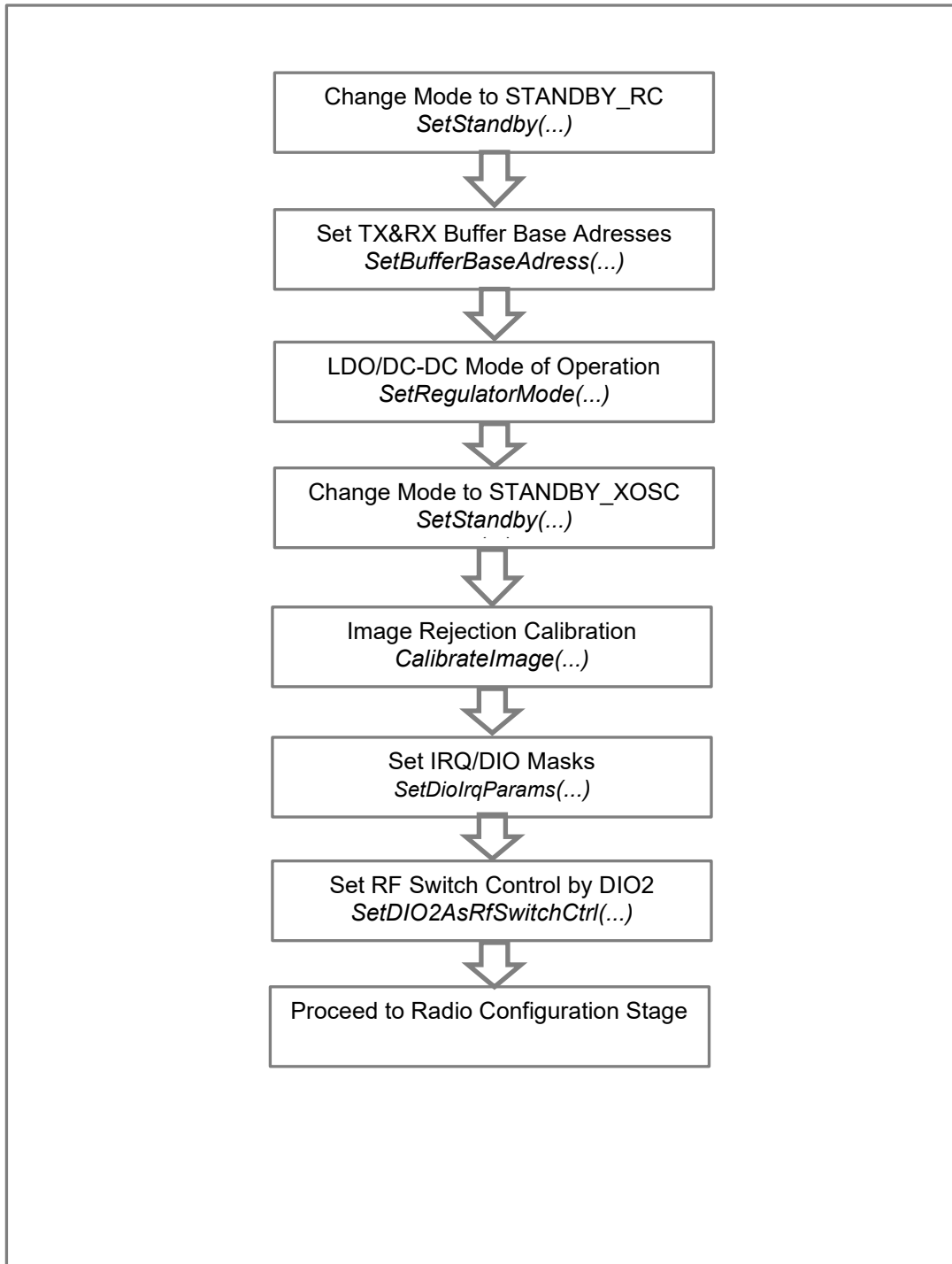

**Fig.7 Configuration and Settings - Standby Mode**

Most of the commands can be sent in any order except for the radio configuration commands which will set the radio in the proper operating mode.

It is mandatory to set the radio protocol using the command *SetPacketType(...)* as a first step before issuing any other radio configuration commands.

In a second step, the user should define the modulation parameter according to the chosen protocol with the command *SetModulationParams(...)*.

Finally, the user should then select the packet format with the command *SetPacketParams(...)*.

**Note:** If this order is not respected, the behavior of the device could be unexpected

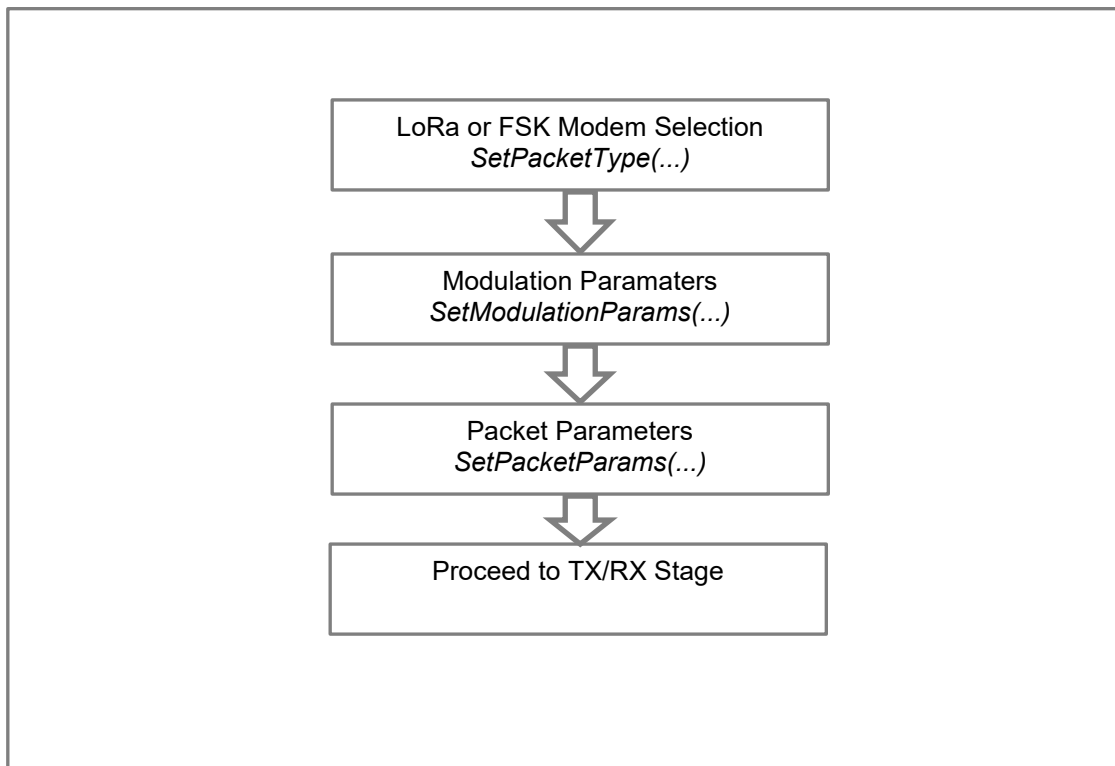

**Fig.8 Configuration and Settings - Modem Selection, Modulation and Packet Parameters**

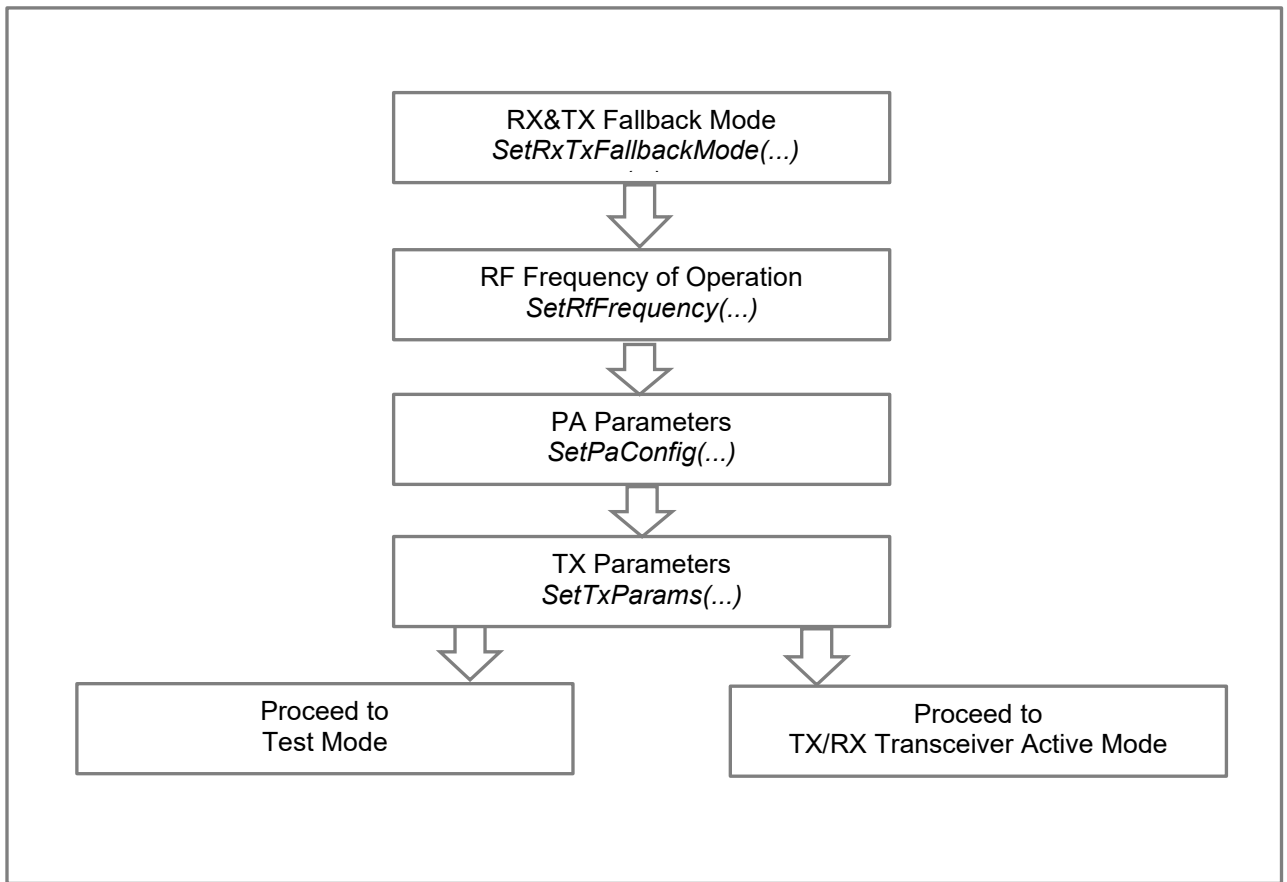

**Fig.9 Configuration and Settings – RF Frequency, PA and TX/RX Parameters**

## 7. Test Setup & Measurement Results

Figure.10 and Figure.11 below depict a simplified diagram used in Transmit Mode RF Output Power/Harmonic measurements and Receive Mode RF Sensitivity/SNR Measurements respectively. Typical measurement results (for TX Mode and RX Mode) are summarized in following tables, Table 22 to Table 27.

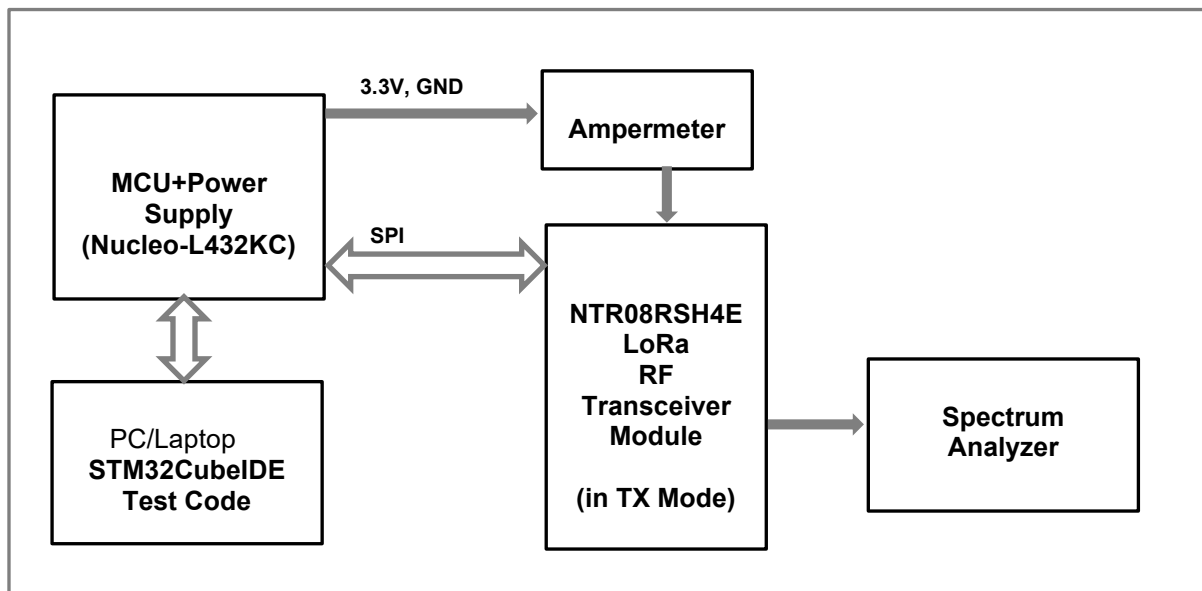

Fig.10 NTR08RSH4E Transmit Mode Test & Measurement Setup

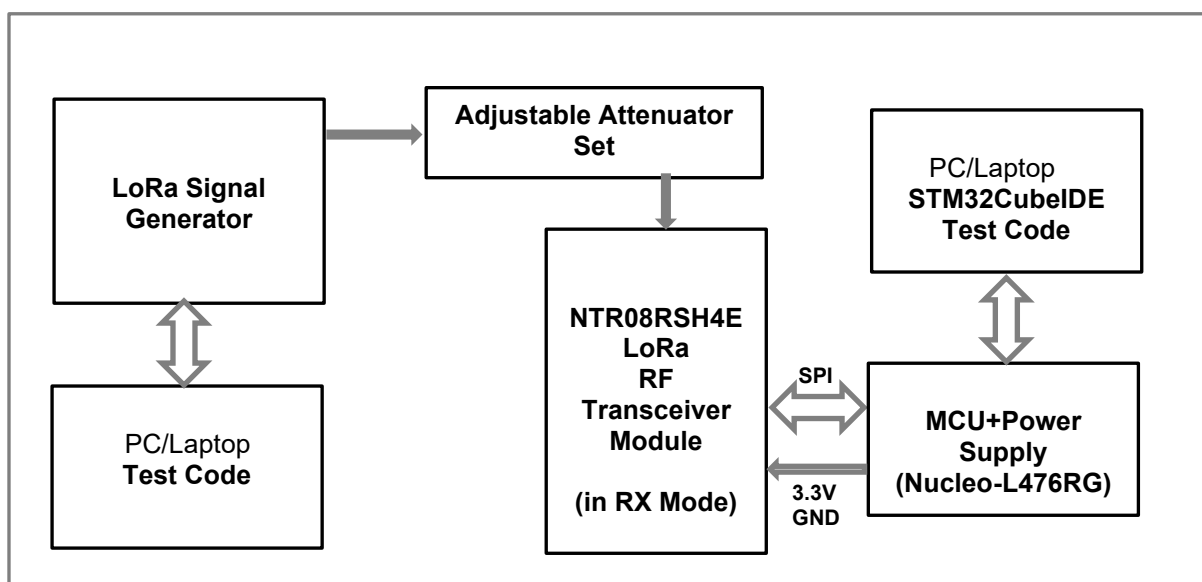

Fig.11 NTR08RSH4E Receive Mode Test & Measurement Setup

## Transmit Mode - RF Output Power and Harmonics

NTR08RSH4E is optimized for +20dBm RF output power (PA SET-4, paDutyCycle-0x04/hpMax-0x07), typical measurement results for other PA settings are provided below in Table 22, Table 23 shows programmable RF power output for selected TX Settings.

PA Settings vs RF Output Level, Harmonic Levels and Current						
Symbol	Description	PA SET-1 0x02/0x02	PA SET-2 0x02/0x03	PA SET-3 0x04/0x06	PA SET-4 0x04/0x07	Unit
$F_{op}$	Operational Frequency/Band	433	433	433	433	MHz
$P_{RFOUT}$	RF Output Power	+12.7	+15.4	+20.1	+20.6	dBm
$P_{RF-sat}$	Current	41	53	92	103	mA
$P_{HL2}$	2nd Harmonic Level	-62.5	-54.6	-46.8	-46.2	dBc
$P_{HL3}$	3rd Harmonic Level	-84.1	-82.2	-71.2	-70.6	dBc
$P_{HL4}$	4th Harmonic Level	-71.2	-68.9	-65.6	-64.1	dBc
$P_{HL5}$	5th Harmonic Level	-78.7	-76.7	-78.2	-75.3	dBc

**Table 22. PA Settings vs RF Output Level and Harmonics**

TX Settings vs RF Output Level, Frequency-433MHz		
PA SET-4, paDutyCycle-0x04/hpMax-0x07		
	TX Setting (Power/Ramp Time)	RF Output Power (dBm)
	0x16	+20.6
	0x13	+18.4
	0x10	+16.4
	0x0D	+13.4
	0x0A	+10.4
	0x07	+7.3
	0x04	+4.3
	0x01	+1.3
	0xFE	-2.8
	0xFB	-5.9
	0xF8	-8.9
	0xF7	-9.9

**Table 23. TX Settings vs RF Output Power**

**Receive Mode - RF Sensitivity and SNR**

Receive Mode RF Sensitivity/SNR Measurements are summarized through Table 24-27 for different SF and BW configurations.

<b>SF/BW&amp;RF Input Level vs RSSI&amp;SNR-----Sample from Measurements</b>				
<b>Frequency Band-433MHz , LoRa Parameters : SF-7, BW-10.4kHz</b>				
	RF Input (TX CW Equivalent)	RSSI Instant/RSSI Packet (dBm)	SNR (dB)	
	-132dBm	0xE4/0xE0	0x21	
		-114/-112	8.25	
	-129dBm	0xDE/0xDC	0x25	
		-111/-110	9.25	
	-126dBm	0xD6/0xD4	0x2C	
		-107/-106	11.00	
	-123dBm	0xD0/0xCC	0x2C	
		-104/-102	11.00	
	-120dBm	0xC8/0xC4	0x2D	
		-100/-98	11.25	
	-110dBm	0xB4/0xB4	0x2C	
		-90/-90	11.00	
	-100dBm	0x9E/0xA0	0x2D	
		-79/-80	11.25	

**Table 25. RF Input vs RSSI & SNR (SF-7/BW-10.4kHz)**

<b>SF/BW&amp;RF Input Level vs RSSI&amp;SNR-----Sample from Measurements</b>				
<b>Frequency Band-433MHz , LoRa Parameters : SF-12, BW-125kHz</b>				
	RF Input (TX CW Equivalent)	RSSI Instant/RSSI Packet (dBm)	SNR (dB)	
	-132dBm	0xDE/0xE4	0xFF	
		-111/-114	-0.25	
	-129dBm	0xDA/0xDE	0x07	
		-109/-111	1.75	
	-126dBm	0xD4/0xD8	0x0F	
		-111/-108	3.75	
	-123dBm	0xCE/0xD0	0x14	
		-103/-104	5.00	
	-120dBm	0xC6/0xC8	0x15	
		-99/-100	5.25	
	-110dBm	0xB2/0xB4	0x17	
		-89/-90	5.75	
	-100dBm	0x9A/0x9C	0x18	
		-77/-78	6.00	

**Table 26. RF Input vs RSSI & SNR (SF-12/BW-125kHz)**

<b>SF/BW&amp;RF Input Level vs RSSI&amp;SNR-----Sample from Measurements</b>				
<b>Frequency Band-433MHz , LoRa Parameters : SF-7, BW-125kHz</b>				
	<b>RF Input (TX CW Equivalent)</b>	<b>RSSI Instant/RSSI Packet (dBm)</b>	<b>SNR (dB)</b>	
	-132dBm	0xE0/0xE0	0x01	
		-112/-112	0.25	
	-129dBm	0xDA/0xDA	0x09	
		-109/-109	1.25	
	-126dBm	0xD6/0xD4	0x12	
		-107/-106	4.50	
	-123dBm	0xCE/0xCC	0x22	
		-103/-102	8.50	
	-120dBm	0xC8/0xC4	0x2B	
		-100/-98	10.75	
	-110dBm	0xB4/0xB0	0x34	
		-90/-88	13.00	
	-100dBm	0x9E/0x9A	0x35	
		-79/-77	13.25	

**Table 27. RF Input vs RSSI & SNR (SF-7/BW-125kHz)**

## 8. Drawings

Figure.12 depicts a description of connector pinout and module dimensions for NTR08RSH4E, a detailed description of the individual pins can be found in Table 28 Connector and Pin Descriptions.

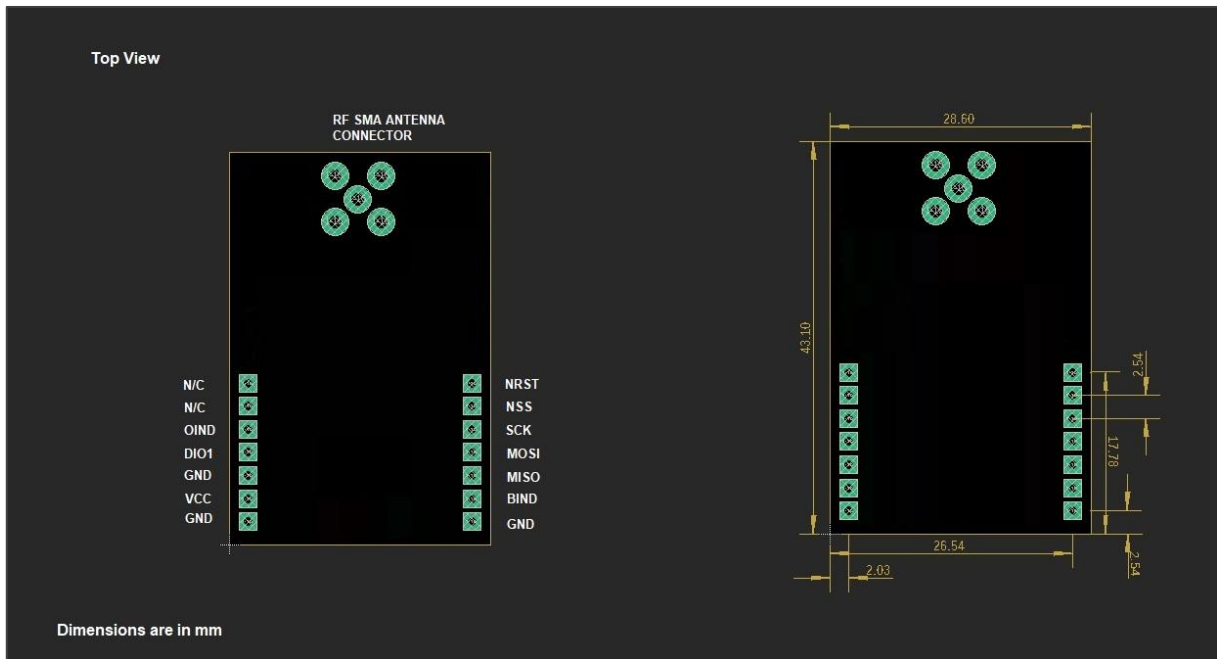

Fig.12 NTR08RSH4E Pin and Size Diagram

CONNECTORS		
Pin No	Pin Name	Pin Function
CA	ANT	RF Output/Antenna
J1-Connector		
J1-1	N/C	No Connection (Internally GND)
J1-2	N/C	No Connection (Internally GND)
J1-3	OIND	Operation Indicator
J1-4	DIO1	Data I/O
J1-5	GND	0V, Ground
J1-6	VCC	+Supply Voltage
J1-7	GND	0V, Ground
J2-Connector		
J2-1	NRST	Reset
J2-2	NSS	SPI chip select
J2-3	SCK	SPI clock
J2-4	MOSI	SPI MOSI
J2-5	MISO	SPI MISO
J2-6	BIND	Busy Indicator
J2-7	GND	0V, Ground

Table 28. Connector and Pin Descriptions(NTR08RSH4E)

## 9. Ordering Information

Order Code	Description	
NTR08RSH4E	NTR08RSH4E 433MHz/+20dBm LoRa RF Transceiver Module (with RF Shield and SMA RF Connector)	

**Table 29. NTR08RSH4E Ordering Info**

## Revision History

Date	Revision	Modifications
August 12, 2024	1.1	Initial release
September 09, 2025	1.2	Addition of Test Setup & Measurements Section, other minor syntax corrections

## References

- 1) Semtech SX1268 Datasheet - <https://www.egn-elektronik.com.tr/EN/Datasheets/SX1268.pdf>
- 2) SX1268 Drivers - [https://github.com/Lora-net/sx126x\\_driver](https://github.com/Lora-net/sx126x_driver)